

**4-CHANNEL STEREO RECEIVER**

**QX-949**

FUW

**OPERATING INSTRUCTIONS**



**PIONEER®**



Pioneer is sincerely grateful that you have selected the QX-949 4-channel Stereo Receiver. Wide flexibility has been designed into this receiver to allow the enjoyment of two and four channel sound in its many varieties. It is compatible with all currently available program sources, including discrete tape and CD-4 discs, RM and SQ matrix records and broadcasts, plus conventional two channel media.

In order to realize the full performance and potentials of this integrated receiver, we recommend that you read this Operating Instructions thoroughly before attempting to operate it.

## INSTALLATION

Before connecting the QX-949 to speakers and other components, determine its location in the listening room. Please note that locations such as the following could lead to deterioration of performance or possible damage.

- Direct sunlight, near radiators or other heat sources
- Places with poor ventilation, high humidity or dust.
- Locations which are not level, unstable or subject to vibration

Do not use or keep volatile materials such as insect sprays near equipment. Prepare a shelf or a stand durable enough to support the QX-949. Due to the 45kHz frequency response required for CD-4 reproduction, do not install the receiver near equipment which may emit interference, such as TV sets, etc.

### ABOUT PROTECTION CIRCUIT

When the power of the QX-949 is turned on, there is an approximately 3 seconds wait before sound can be heard from the speakers. This is to prevent surge currents from possibly damaging transistors or speakers. If sound is not heard after 3 to 6 seconds, turn off the power and inspect speaker connections.

During playing, if sounds stop or a continuous relay switching sound develops, possible speaker shorting is indicated. Turn off the power and inspect speaker connections, wiring and speaker impedance.

The protection circuit is self-resetting. After the problem is rectified, normal playing can be resumed.

## CONTENTS

Installation .....	2
QX-949 Features .....	3
4-channel System Composition .....	4
Speaker System Installation .....	5
Speaker Connection .....	6
Antenna and Ground Connections .....	7
Turntable Connection .....	8
AUX Input Terminals .....	8
About 2CH Power Boosting Switch .....	8
Tape Deck Connection .....	9
Connection Diagram .....	10
Front Panel Facilities .....	12
Before Playing .....	14
FM and AM Broadcasts .....	15
Playing CD-4 Records .....	16
Playing 2-channel and Matrix Records... ..	17
Tape Deck Operation .....	18
Employing DOLBY* NR ADAPTOR Terminals .....	19
Using the AUX Terminals .....	20
4CH MPX Output Terminal .....	20
Conditions Frequently Mistaken for Malfunction .....	21
CD-4 Technical Outline .....	22
Matrix 4-channel Records .....	23
Specifications .....	24

\*The word 'Dolby' is a trademark of Dolby Laboratories Inc.



# QX-949 FEATURES

## Built-in CD-4 Demodulator

Superb frequency response and separation are provided by the phase lock loop circuit with FET. Extremely stable operation is assured even with well used records. Furnished test record is supplied for adjusting carrier level and separation.

## RM & SQ Decoders

Built-in high performance decoders for Regular Matrix (RM) and SQ matrix deliver top performance in either program source format.

## Power Select Feature

Less output power per channel is required for comfortable 4-channel listening than for 2-channel operation. The power select feature allows the user to choose between 4 channels at 53W each or 2 channels at 75W each (with less than 0.3% harmonic distortion at 8 ohms).

## Power Amplifier

Four 10,000 $\mu$ F large capacity electrolytic capacitors are employed in the low internal resistance power supply to yield an exceptionally wide power bandwidth. All stages of the high output, low distortion amplifier utilize direct coupled complementary OCL (output capacitor-less) circuit. Output throughout the range from 20Hz to 20kHz is 40W x 4 (with less than 0.3% harmonic distortion at 8 ohms).

## Tone Control Amplifier

Individual tone controls are provided for both front and rear channels. The transistorized negative feedback design results in excellent signal-to-noise ratio with contour-less variation characteristics.

## Unique 4-channel Level Indicator

All four-channel output levels are simultaneously displayed for easy one-glance comparison. A push button attenuator system adjusts indicator sensitivity. This indicator is convenient for the proper adjustment of CD-4 separation while employing the furnished test record.

## MOS FET & 4-ganged Tuning Capacitor Front End

Dual gate MOS field effect transistors are employed in the FM high frequency amplifier and mixing stages. Sensitivity, Signal-to-Noise ratio and intermodulation distortion factors are vastly improved. Coupled with the full-coverage 4-ganged tuning capacitor, this highly advanced design provides superb handling of spurious response, imaging, cross modulation and other FM parameters. Stable reception is assured even in high field strength locations by the buffer equipped tuning oscillator.

## High Performance -- High Reliability IC

Three 2-element phase linear ceramic filters, three stage differential amplifier, diode limiter, and quadrature detector circuits are contained in the IF section. Superior performance design provides low noise, low distortion FM enjoyment. Wide-band stable separation is obtained by the IC stereo decoding circuit.

## Comfortable FM Enjoyment

Unpleasant inter-station noise during FM station selection is eliminated by the FM muting circuit which operates from the IF amplifier and FM detector voltage. Truly comfortable operation is obtained. An FM multiplex noise filter is also contained for reducing noise during stereo broadcasts.

## IC & Ceramic Filter AM Tuner

The AM tuner employs a 3-ganged tuning capacitor and alignment type high frequency amplifier. Imaging and IF interference are greatly reduced. Superb selectivity and frequency response are provided by the IC and ceramic filter IF amplifier, while interference and distortion are minimized by the balanced mixer circuit. The frequency converter also employs a balanced mixer for refreshing AM sound quality even in strong field locations.

## Recorded Tape Duplication

Since connecting terminals for 2-channel and 4-channel tape decks are provided, together with a tape monitor switch, persons owning two 4-channel tape decks can duplicate four-channel recorded tape. Persons owning a 2-channel and a 4-channel tape deck can record and edit by desired mode (CD-4, RM Matrix or SQ Matrix).

## PERFORMANCE

The QX-949 is an integrated 4-channel stereo receiver which can operate with both conventional 2-channel and 4-channel program source. Functions in the 2-channel mode are: 2-channel stereo record playing, FM stereo reception, AM reception, tape deck record and playback, and auxiliary source.

The 4-channel Functions of the QX-949 are:

1. 4-channel Discrete Reproduction  
Four-channel record reproduction with CD-4 phono cartridge equipped turntable; four-channel tape reproduction from 4-channel tape deck.
2. 4-channel Matrix Reproduction  
Regular Matrix (RM) and SQ matrix record reproduction, FM matrix 4-channel broadcast reception.
3. Matrix Reproduction of 2-channel Program Source.  
RM or SQ matrix reproduction can be performed with 2-channel program sources such as stereo records, tape, and FM stereo.



# 4-CHANNEL SYSTEM COMPOSITION

Fig. 1 illustrates the equipment that can be connected to the QX-949 for composing a 4-channel stereo system. The basic system consists of four speakers and two turntables. Other equipment, which can be procured individually at a later time, includes Dolby Adaptor, second set of front and rear speakers, one or more tape decks (open reel, cassette), cartridge tape player, and various additional accessories. Although wide flexibility is featured, certain care is recommended in the selection of turntable and phono cartridge. These are discussed below.

## TURNTABLE

CD-4 records are cut by employing a 30kHz high frequency carrier signal, which expands the bandwidth up to 45kHz. A lower recording level is also used in comparison to conventional 2-channel records. These factors place considerable demands on the selection of a turntable. The following points should be noted.

- **Phono motor** should be low vibration, revolve at proper speed, minimum wow and flutter, and high quality Signal-to-Noise ratio.
- **Tonearm** should employ low tracking force and be equipped with anti-skating and lateral balance adjusting provisions for regulating relative stylus pressure between left and right record groove walls.
- The turntable connecting cord should be of low capacitance and have suitable frequency handling characteristics for high audio bandwidth.

## PHONO CARTRIDGE

A phono cartridge specially designed for CD-4 reproduction is essential for playing CD-4 records. Use particular care during phono cartridge installation that the stylus is perpendicular to the record surface. Improper installation may result in reduced sound quality and poor separation.

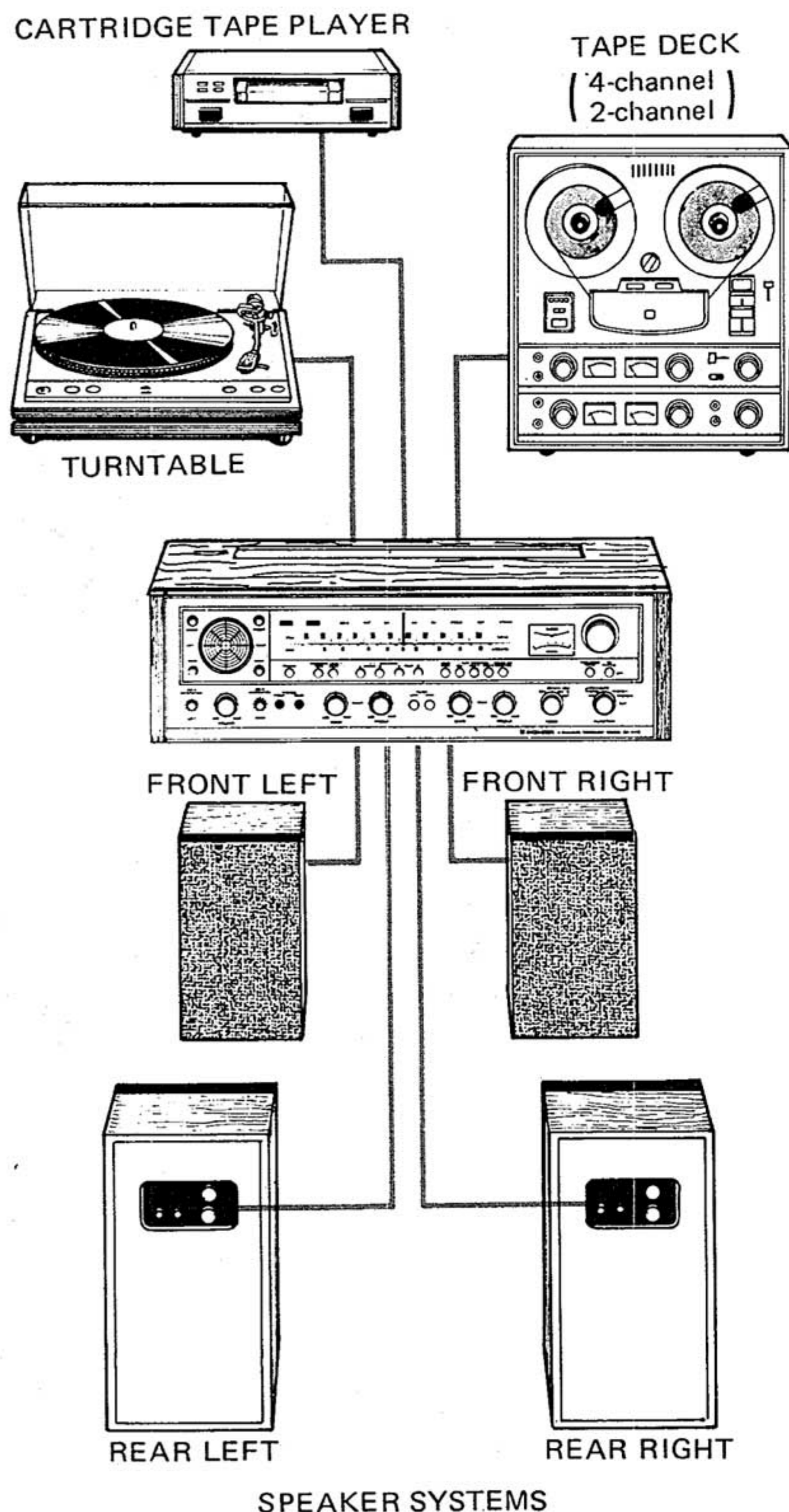

Fig. 1



# SPEAKER SYSTEM INSTALLATION

4-channel stereo reproduction speakers employ four installed speakers as shown in Fig. 2.

Front Left Speaker	FRONT LEFT (CH 1)
Front Right Speaker	FRONT RIGHT (CH 3)
Rear Left Speaker	REAR LEFT (CH 2)
Rear Right Speaker	REAR RIGHT (CH 4)

The QX-949 is provided with terminals for two sets of front and two sets of rear speakers (A & B). As illustrated in Fig. 2, according to room size, playing effect or program source, selection of each set of speakers can be performed by the SPEAKERS switch. If the additional set is installed in another room, simultaneous playing can be performed.

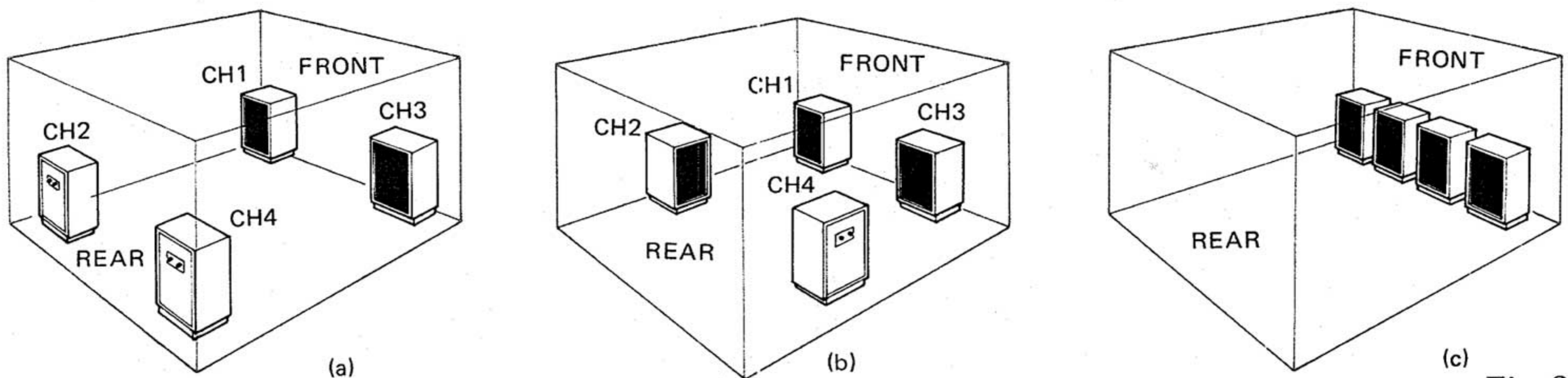

Fig. 2

## SPEAKERS

Ideally, all four speakers should have equal performance characteristics. While this is difficult to attain in practice, the left and right front speakers should be equal. The left and right rear speakers should then be matched as closely as possible to the front speakers.

Select speakers with nominal impedances between 4 and 16 ohms. Superior quality should be sought in terms of efficiency, frequency response, crossover, directionality, and other characteristics.

Personal sound preference, space limitations, decor, etc. can be employed in selecting from the various available styles of good quality speakers on the market. Enclosures may be bass reflex or air-suspension, bookshelf or floor standing. Full range, 2-way, and 3-way are among the varieties of speaker composition.

## SPEAKER PLACEMENT

The listening room is an integral part of a stereo system and is equal in importance to any other component. Speaker location, room composition, size, furniture distribution and other factors play large roles in stereo reproduction. In general, bass is enhanced when a speaker is placed in front of a wall. Excessive sound brightness is sometimes experienced with hard room floors, low ceiling, or hard wall facing the speaker. Considerable improvement is often realized by installing a rug on the floor or a pleated curtain on the wall. Changing furniture distribution is an effective measure in many cases.



# SPEAKER CONNECTION

Speaker system connections are as follows:

Speaker Terminals	Speaker Position	Channel
FRONT A or B	FRONT-LEFT	CH 1
	FRONT-RIGHT	CH 3
REAR A or B	REAR-LEFT	CH 2
	REAR-RIGHT	CH 4

As shown in Fig. 4, upper and lower terminals are provided for each speaker. The upper red is plus (+) and the lower black is minus (-). Since speakers are also polarized in the same manner, be sure to connect them plus to plus (red) and minus to minus (black). If all four channels are not connected in proper polarity, the 4-channel effect will be lost.

**NOTE:**

If two pairs of speakers are to be used at the same time (A + B), each speaker must have an impedance of 8 ohms or more.

## Speaker Lead Wire Preparation & Connection (Fig. 5)

1. Strip about 10mm (3/8 inch) of the insulation from the end of the speaker lead wire.
2. If the conductor is stranded, twist the strands together so they do not come loose.
3. Depress the black colored lever of the speaker terminal and insert the speaker minus lead wire into the hole below the lever. Return lever to its former position.
4. Push up the red colored lever of the speaker terminal and insert the speaker plus lead wire into the hole below the lever. Return the lever to its former position.

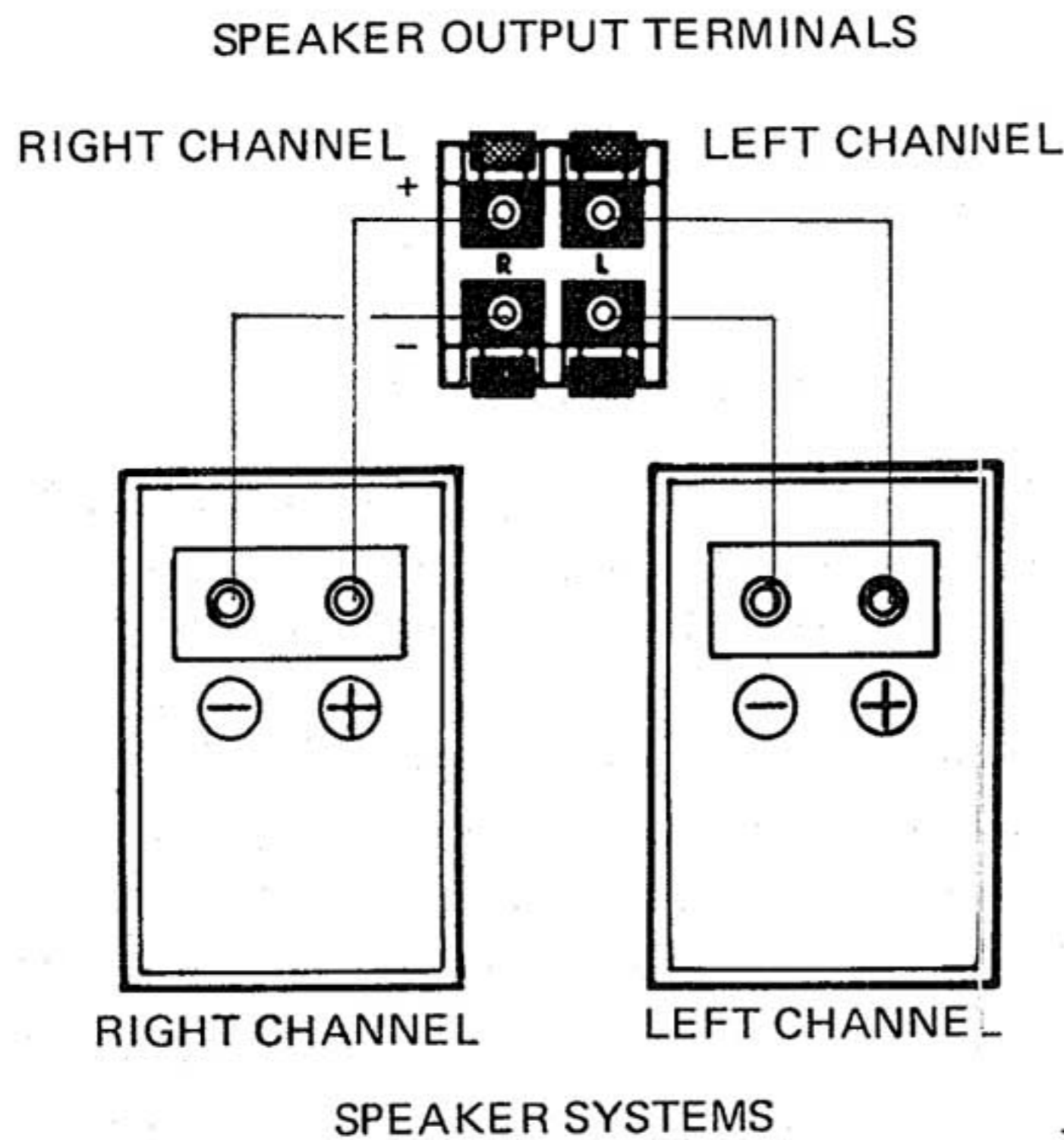

Fig. 4

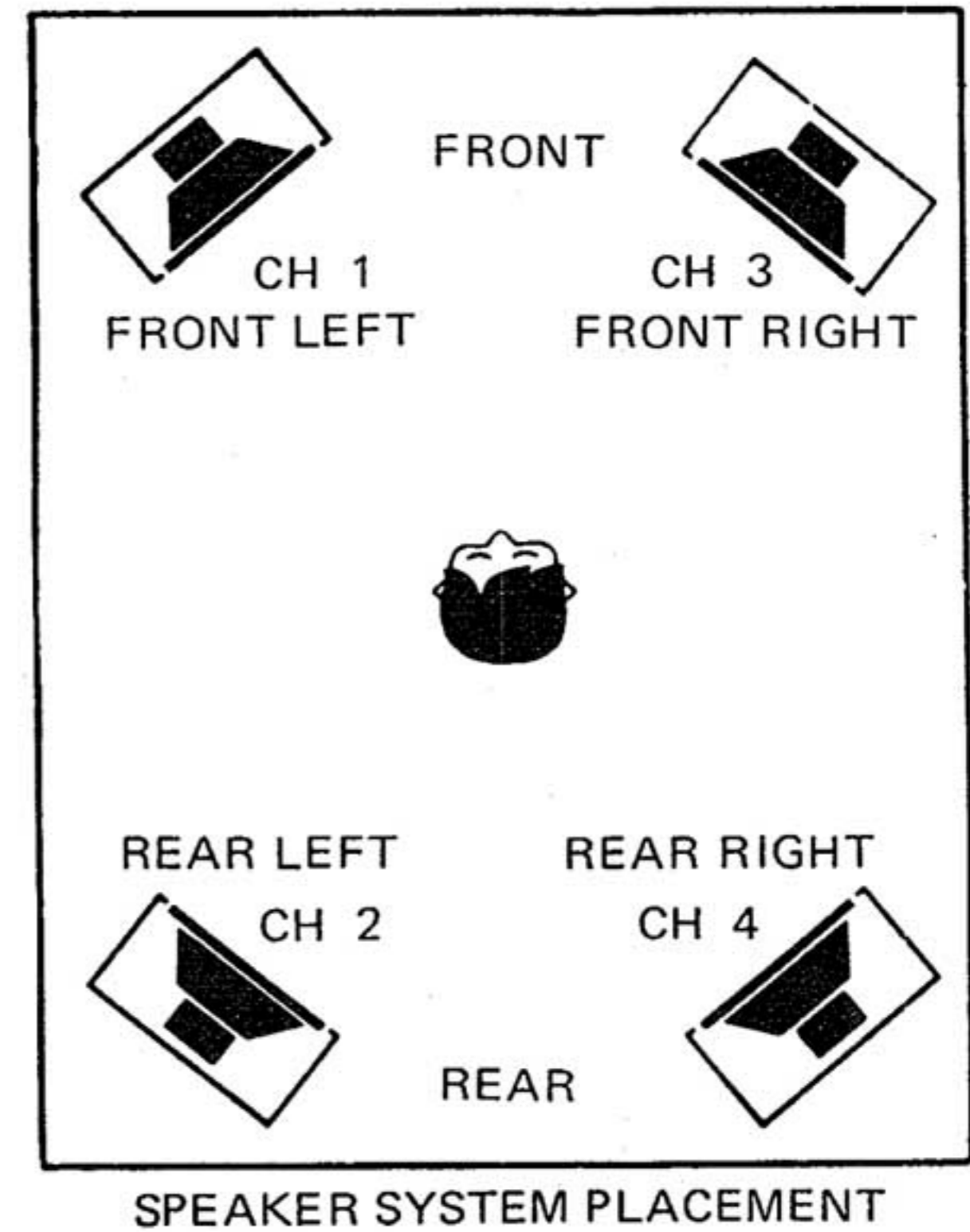

Fig. 3

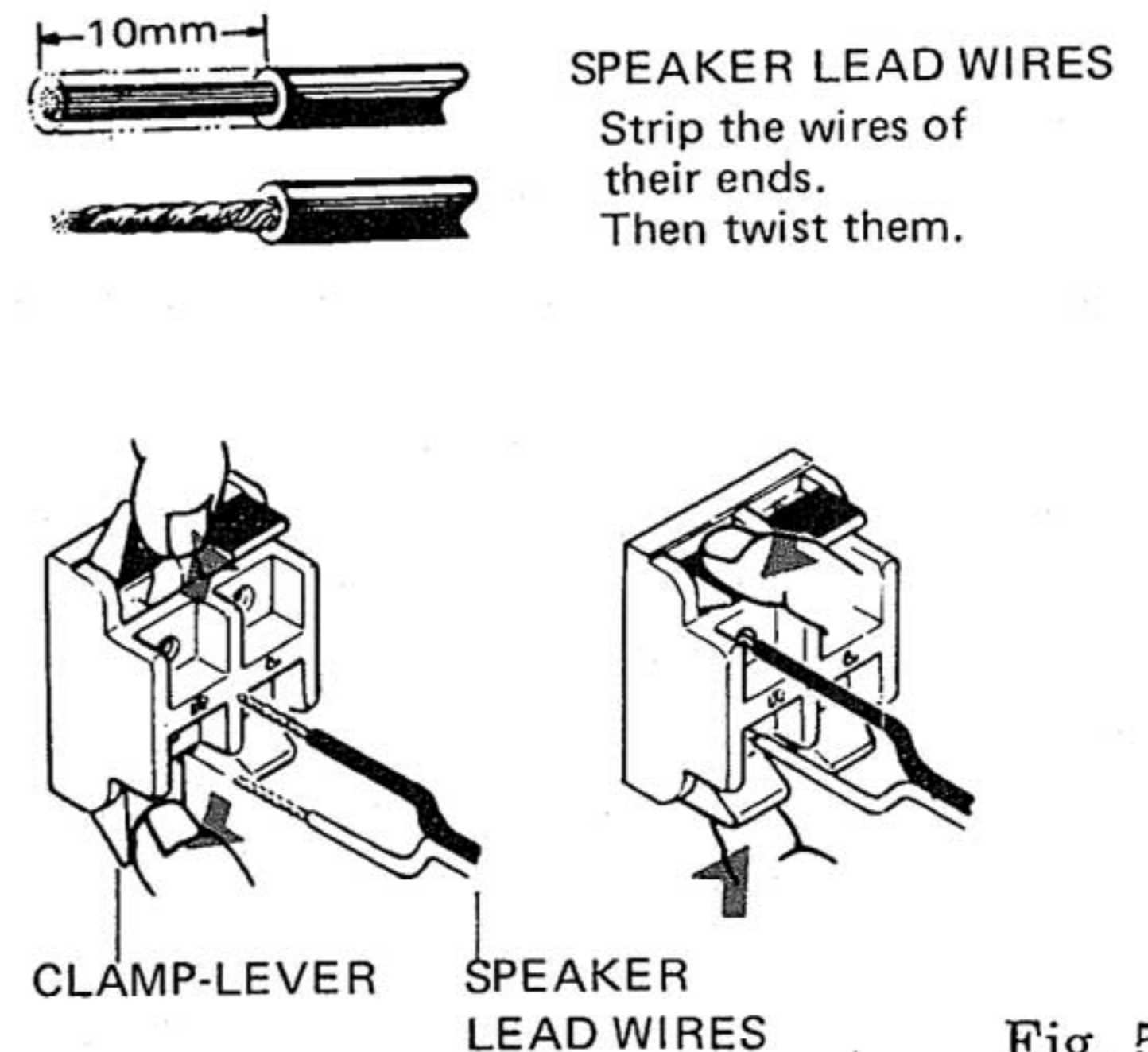

Fig. 5



# ANTENNA AND GROUND CONNECTIONS

## FM ANTENNA

Due to their short wave length, FM broadcast signals are sharply affected by obstructions such as buildings and steel structures. Selection of the proper FM antenna requires careful consideration of factors including signal strength, broadcast station distance and direction.

**Special FM Antenna:** A special FM antenna is required when stations are distant or when interfering objects are present. An outdoor FM antenna (or FM & TV combined antenna) can be installed and connected to the FM ANTENNA terminals of the QX-949 by feeder wire. Since a variety of FM antennas are available consult an audio dealer for best selection.

### NOTE:

Urban areas with heavy traffic, industrial zones, or locations near high voltage power lines may experience interference even with a special FM antenna. In such cases seek the advice of an audio dealer. It may be advisable to employ 75-ohm coaxial cable to connect the antenna to the QX-949. 75-ohm cable is connected as shown in Fig. 7.

**T-type Dipole Antenna:** The furnished T-type dipole antenna can be used where FM signals are strong. Connect it to the antenna terminals as shown in Fig. 8. While listening to an FM station, spread the T section horizontally and determine its best orientation. Secure it to a wall or ceiling. See FM Reception section on page 15.

## AM ANTENNA

Refer to the section on AM Reception on page 15. While listening to an AM station, position the ferrite antenna for best reception as shown in Fig. 9.

**AM Lead Wire Antenna:** If positioning the ferrite antenna does not provide satisfactory AM reception, connect vinyl insulated antenna wire to the AM ANTENNA terminal and stretch out the other end of the wire as high as possible. Secure it to a wall or ceiling. (Fig. 6).

**Outdoor AM Antenna:** If reception is still difficult after attempting the above, an outdoor AM antenna can be suspended between two poles and connected with vinyl insulated lead wire to the AM ANTENNA terminal (Fig. 8).

## GROUND

For maximum safety and noise elimination, connect the GND terminal to an earth ground if at all possible. See Fig. 6.

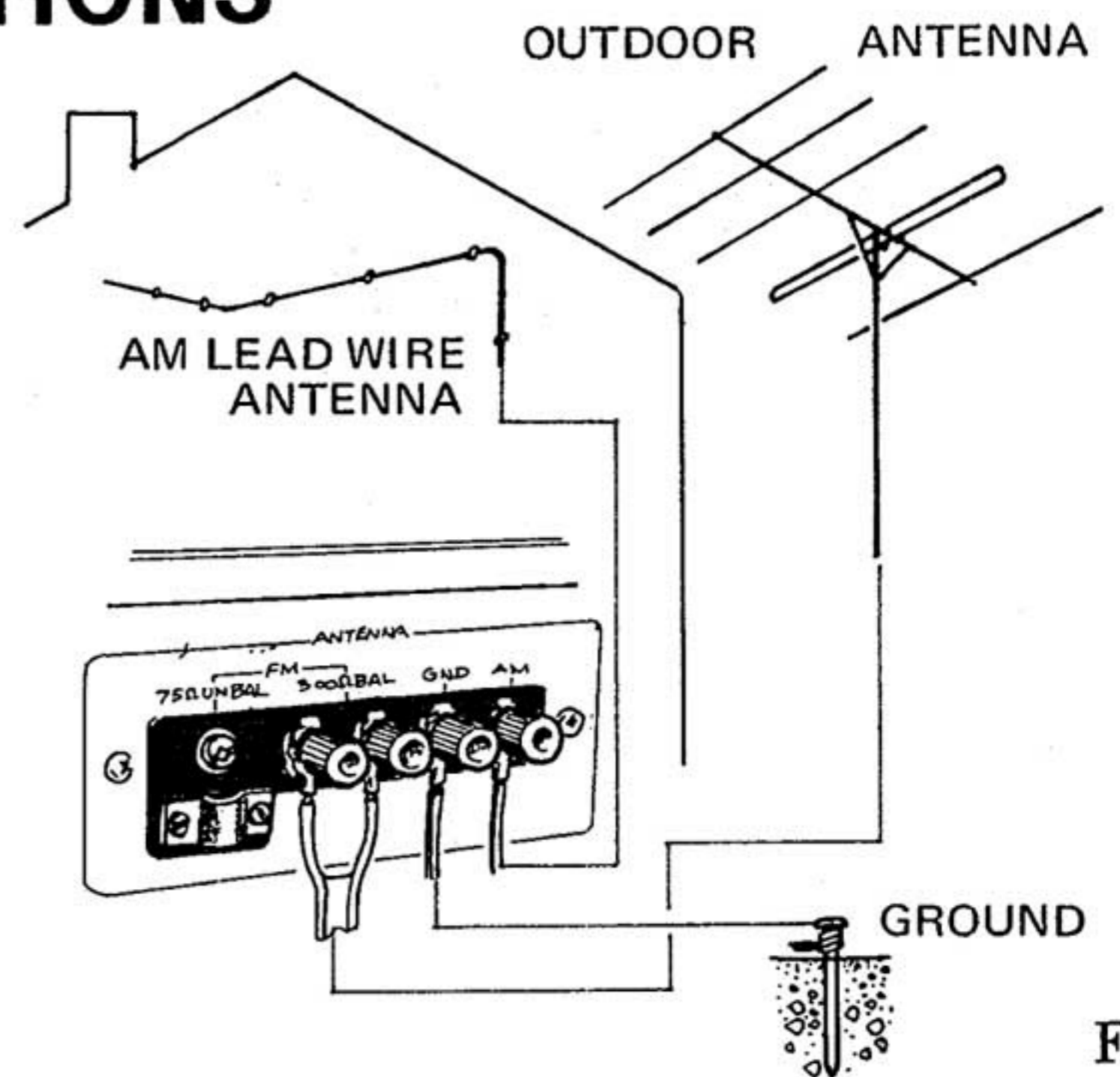
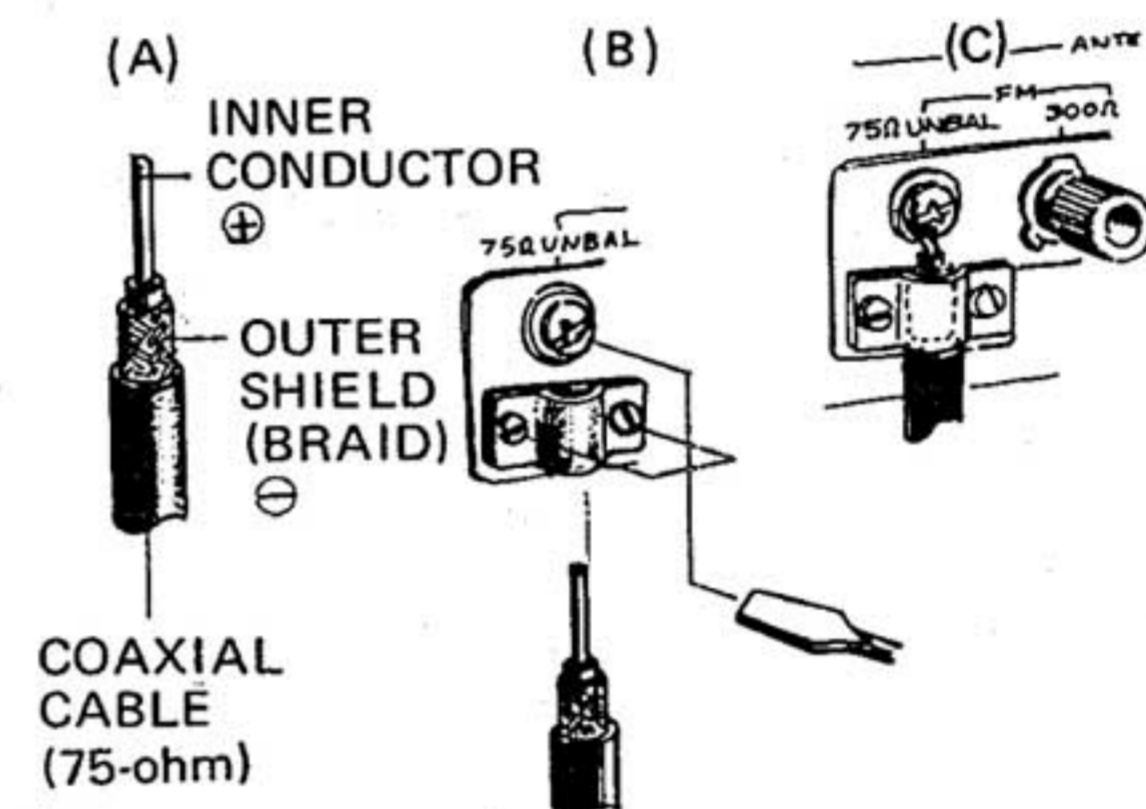

Fig. 6



Strip the coaxial cable as shown in (A). Loosen the screws and connect the cable as shown in (B). Then tighten all screws for a connection like (C).

Fig. 7

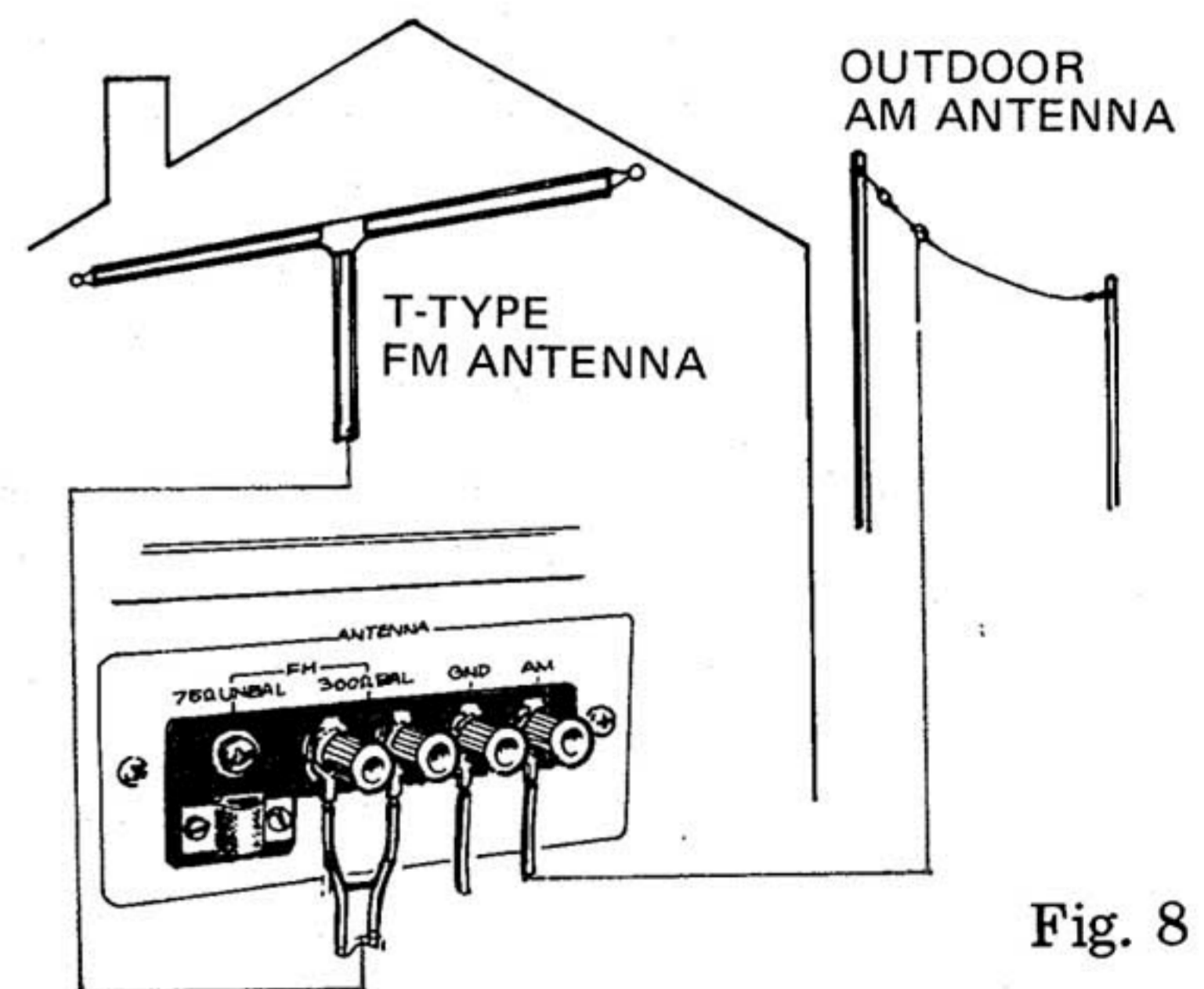
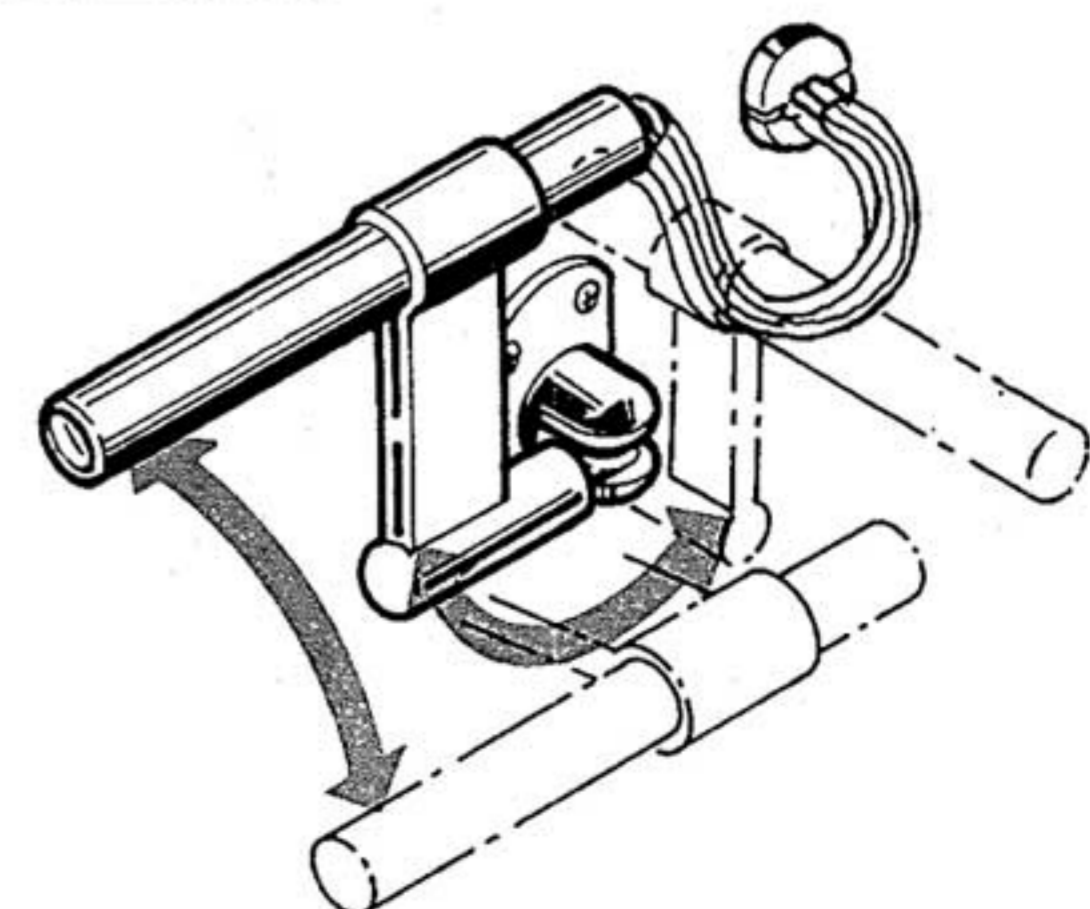

Fig. 8



AM FERRITE ANTENNA

Fig. 9



# TURNTABLE CONNECTION

As illustrated in Fig.10, connect the turntable left channel to the PHONO 1 L (CH 1) terminal, and the turntable right channel to the R (CH 3) terminal.

If the turntable is provided with a ground wire, connect it to the GND terminal below the PHONO inputs.

When two turntables are used at the same time, connect the second turntable to PHONO 2 terminals.

Employ the following cartridges according to the type of records to be played.

- |                        |   |                     |
|------------------------|---|---------------------|
| Conventional 2-channel | } | Magnetic cartridge  |
| Regular matrix (RM)    |   |                     |
| SQ matrix              |   |                     |
| CD-4 discrete          |   | CD-4 type cartridge |

**NOTE:**

Be sure to employ an auxiliary transformer or head amplifier when using moving coil (MC) cartridges.

# AUX INPUT TERMINALS

These terminals are L and R (CH 1 & CH 3) input connectors for 2-channel program sources such as cartridge tape player, TV tuner, etc. Upper terminal is left channel and lower terminal is right channel.

# ABOUT 2CH POWER BOOSTING SWITCH

To increase available power when using the QX-949 for 2-channel reproduction, a convenient power select feature is incorporated. The covered compartment on the rear panel houses a reversible connector panel. When added power is desired during 2-channel operation, open the cover, remove the connector panel and rotate it 180°, then re-insert it and close the cover. Be sure to reverse the connector again before returning to 4-channel operation.

When opening the cover, power is turned off.

These illustrations show how the boosting switch is available.

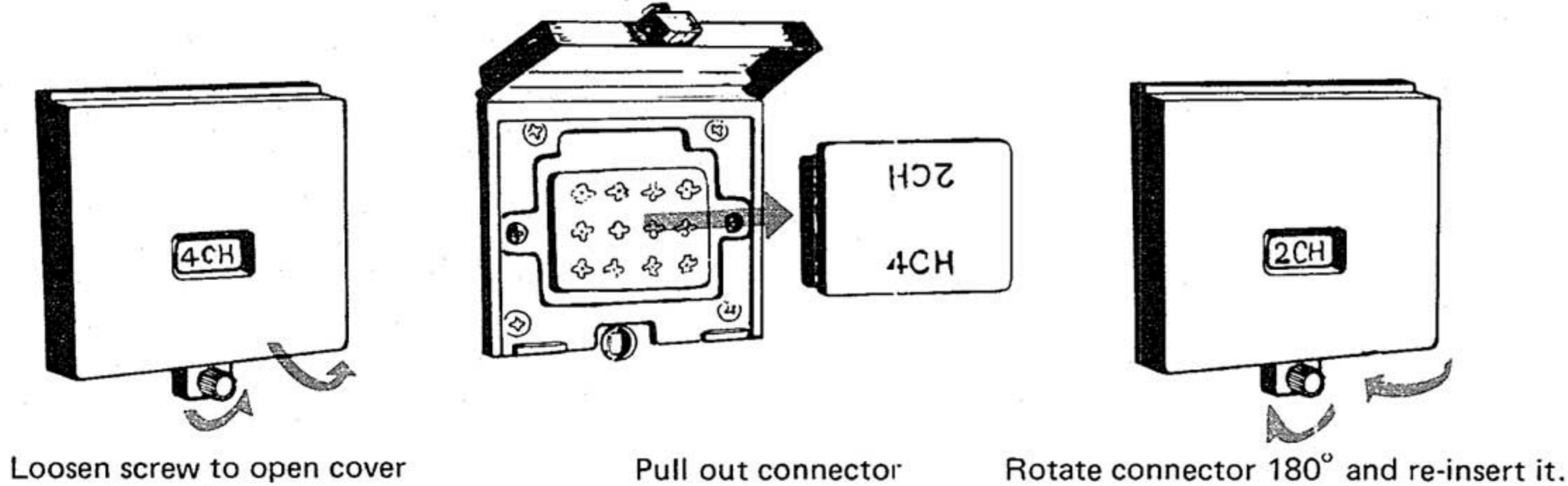

Fig. 11

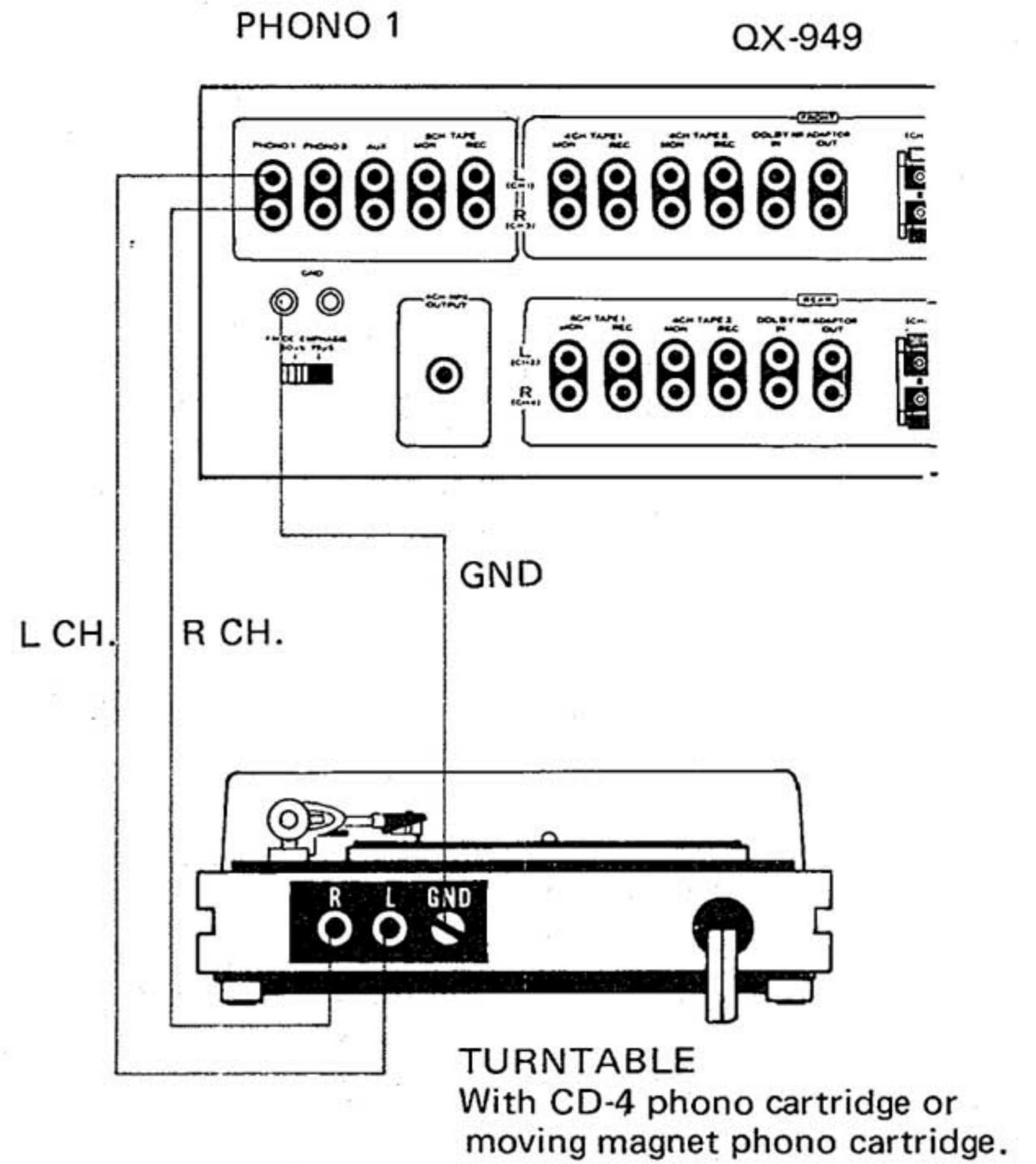

Fig. 10



# TAPE DECK CONNECTION

The tape recording and playback can be performed through either a 2-channel or 4-channel tape deck (open reel or cassette) connected to the 2CH TAPE or 4CH TAPE 1 terminals of the QX-949.

Employ the connecting cords generally supplied with the tape deck. When using two or three 4-channel tape decks at the same time, connect the second tape deck to 4CH TAPE 2 terminals, connect the third tape deck to DOLBY NR ADAPTOR terminals.

## CONNECTIONS FOR RECORDING

Connect the TAPE REC terminals of the QX-949 to the recording input (LINE INPUT) terminals of the tape deck. Be sure to connect each terminal properly. Refer to Fig. 12.

For the same purpose, use the DOLBY NR ADAPTOR OUT terminals.

## CONNECTIONS FOR PLAYBACK

Connect the TAPE MON terminals of the QX-949 to the playback output (LINE OUTPUT) terminals of the tape deck. Be sure to connect each terminal properly, as shown in Fig. 13.

For the same purpose, use the DOLBY NR ADAPTOR IN terminals.

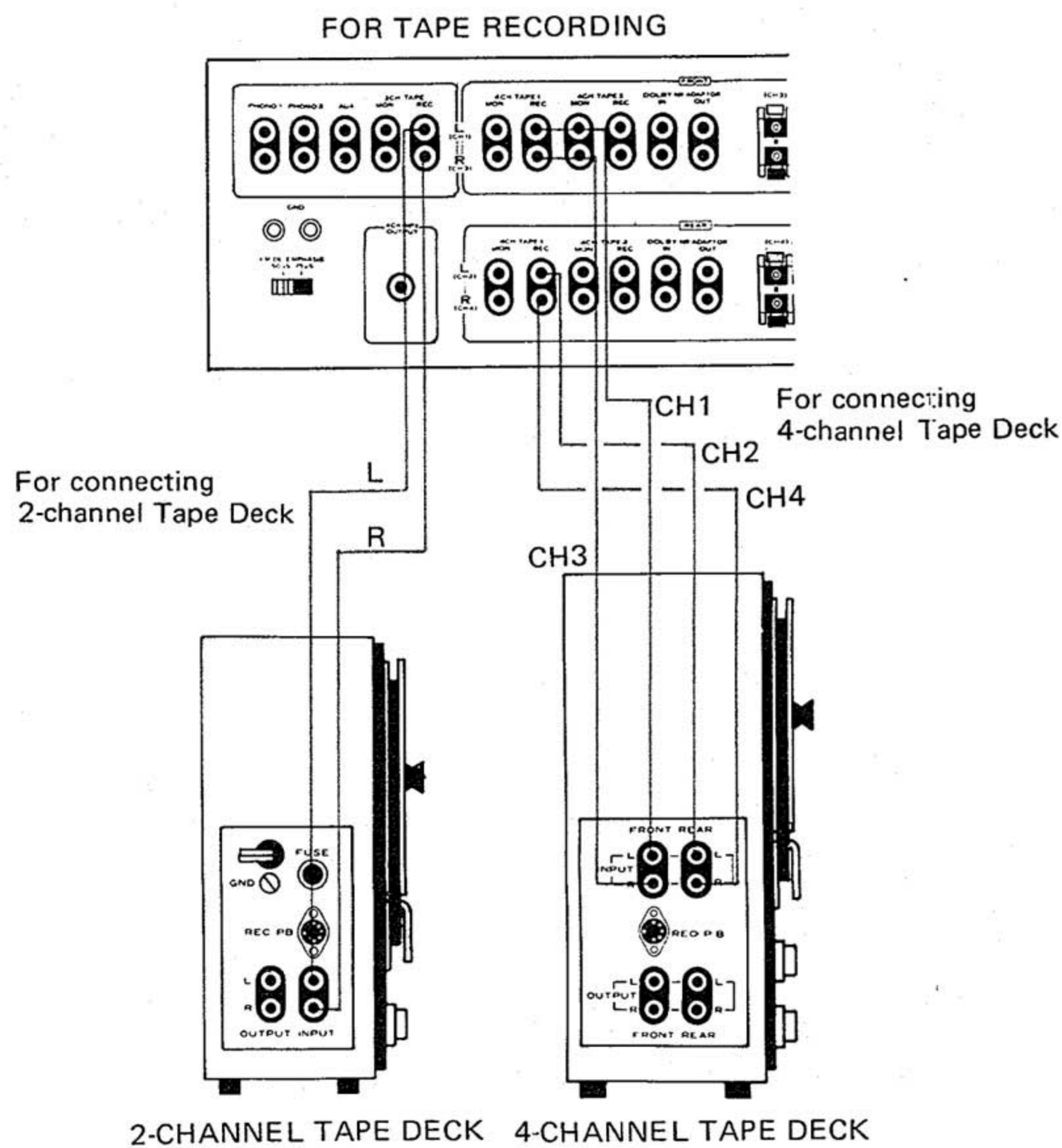

Fig. 12

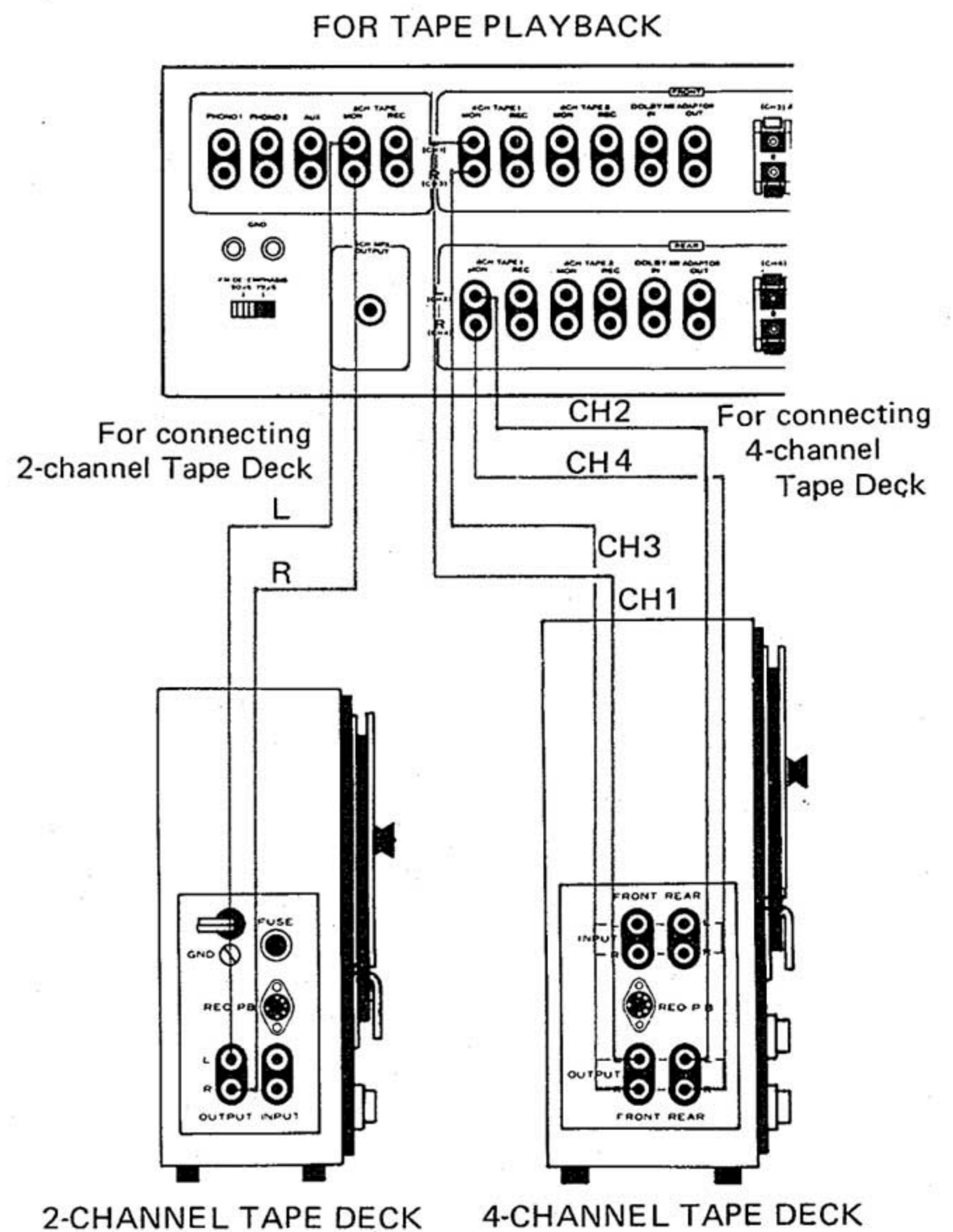
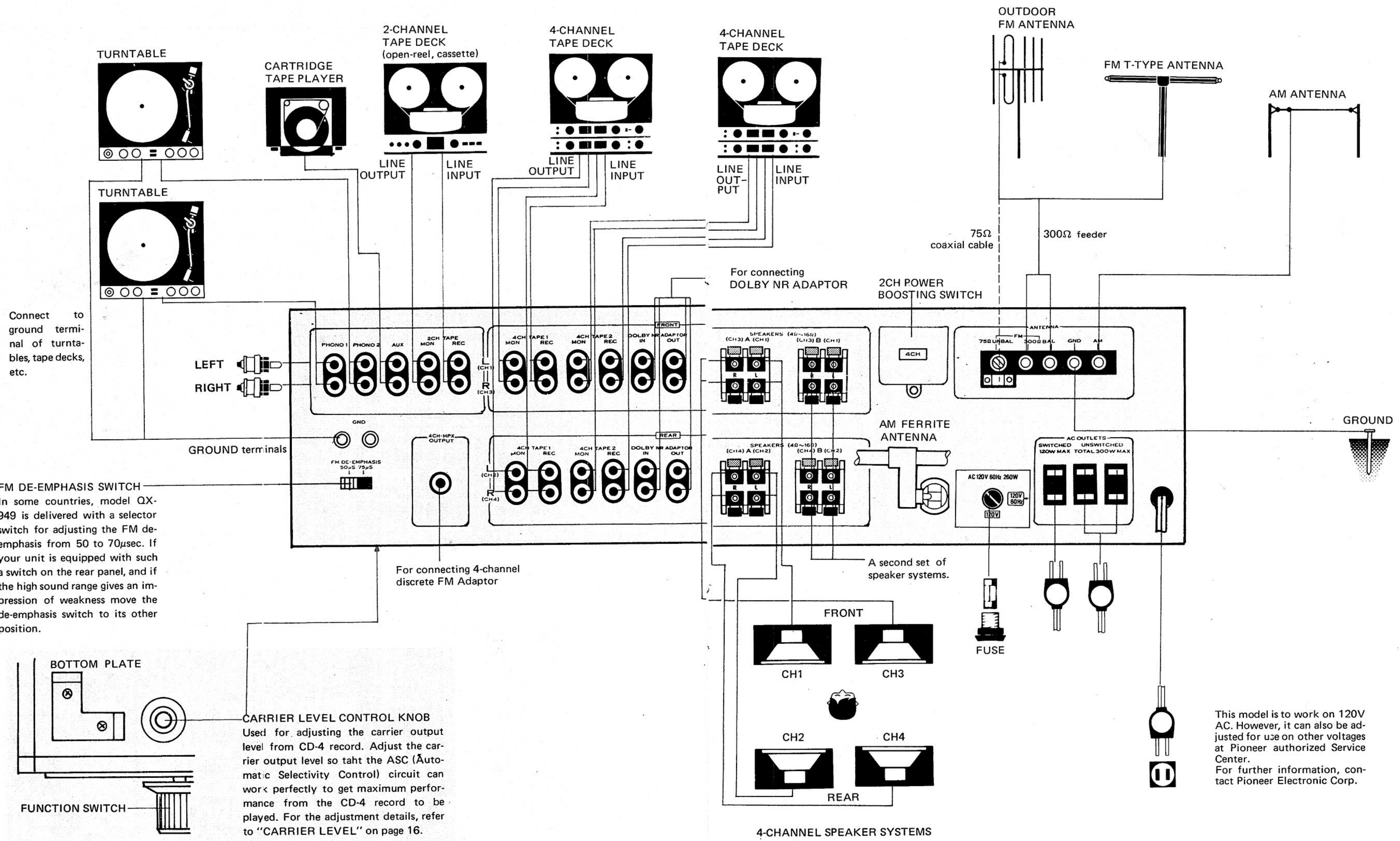

Fig. 13



# CONNECTION DIAGRAM



Connect to ground terminal of turntables, tape decks, etc.

**FM DE-EMPHASIS SWITCH**  
 In some countries, model QX-949 is delivered with a selector switch for adjusting the FM de-emphasis from 50 to 70µsec. If your unit is equipped with such a switch on the rear panel, and if the high sound range gives an impression of weakness move the de-emphasis switch to its other position.

**CARRIER LEVEL CONTROL KNOB**  
 Used for adjusting the carrier output level from CD-4 record. Adjust the carrier output level so that the ASC (Automatic Selectivity Control) circuit can work perfectly to get maximum performance from the CD-4 record to be played. For the adjustment details, refer to "CARRIER LEVEL" on page 16.

This model is to work on 120V AC. However, it can also be adjusted for use on other voltages at Pioneer authorized Service Center. For further information, contact Pioneer Electronic Corp.



## FRONT PANEL FACILITIES

### POWER SWITCH

Push button switch for turning on AC power. Also activates switched AC outlets on rear panel. Depress once for power ON; depress again for power OFF.

### BALANCE CONTROLS

Individual balance controls for each of the four stereo channels.

### 4-CHANNEL LEVEL INDICATOR

All channels simultaneously displayed; relative intensity easily compared and adjusted.

### VOLUME CONTROL

Control for adjusting sound volume. When rotated clockwise, 4-channel speaker sound increases.

### CD-4 SEPARATION CONTROLS

Controls for adjusting front and rear separation when playing CD-4 records using a CD-4 cartridge.

Please refer to page 16 section on CD-4 channel separation adjustment procedures for detailed information. After adjustment, 2-channel records and matrix 4-channel records can also be played at the same setting.

When playing records employing a conventional 2-channel cartridge, set these controls (left & right) to center position.

**LEFT Control:** Front left (CH 1) and rear left (CH 2) separation adjustment.

**RIGHT Control:** Front right (CH 3) and rear right (CH 4) separation adjustment.

Be sure to readjust when replacing cartridge or stylus.

### PHONES JACKS (FRONT & REAR)

Accept stereo headphone jacks. Front left and right (CH 1 & CH 3) can be heard when using FRONT jack.

Rear left and right (CH 2 & CH 4) can be heard when using REAR jack.

### INDICATOR LEVEL BUTTONS

Step attenuator switches convenient for reading of the 4-Channel Level Indicator. If both buttons are depressed, their values are added. According to button positions, each attenuation of 0dB, -10dB, -20dB and -30dB can be selected: 0dB at released position, -10dB and -20dB pushed, and -30dB can be obtained by pushing -10dB and -20dB buttons.

### SPEAKER SWITCHES

Up to four pairs of speakers can be connected and switched on and off (in pairs) with the SPEAKERS SWITCH buttons.

Button depressed: respective pair of speakers in operation.

Button released: respective pair of speakers off. By depressing all four buttons 2 sets of four-channel speaker systems can be used simultaneously (in different rooms, etc.).

### BASS & TREBLE CONTROLS

Separate controls are provided for front and rear bass and treble.

### FILTER BUTTON

**LOW:** Use this filter to cut out low-frequency noise (hum, rumble).

**HIGH:** Use this filter to cut out high-frequency noise (hiss).

### LOUDNESS BUTTON

Depress when listening at low volume levels for proper sound balance relative to human ear sensitivity.

### TAPE MONITOR BUTTONS (2CH, 4CH-1, 4CH-2)

These buttons are set to ON for checking the recording conditions or for playback with tape decks.

**2CH:** This button is set to ON for monitoring a recording in progress or for playback with a 2-channel tape deck connected to the 2CH TAPE MON and REC terminals.

**4CH-1:** This button is set to ON for monitoring a recording in progress or for playback with a 4-channel tape deck connected to the 4CH-1 TAPE MON and REC terminals.

**4CH-2:** This button is set to ON for monitoring a recording in progress or for playback with a 4-channel tape deck connected to the 4CH-2 TAPE MON and REC terminals.

**NOTE:** For record/playback or listening to broadcasts, leave these buttons set to the OFF position. With the button set to ON no sound will be heard.

### DOLBY NR ADAPTOR BUTTON

Depress when employing Dolby Noise Reduction Adaptor for recording or playback.

### CD-4 INDICATOR LAMP

This lights to indicate that CD-4 record is being played (only when the MODE switch is set at 4CH CD-4).

### MODE & FUNCTION INDICATORS

Separately lighted indicators provide one-glance recognition of the QX-949 operating mode and function. Left to right: 2CH, 4CH, CD-4, RM, SQ, AM, FM, PHONO, AUX, STEREO (FM stereo indicator)

### TUNING/SIGNAL METER

When selecting an AM broadcast, tune so that the dial pointer of the lower meter deflects as far to the right as possible. For an FM broadcast, use the lower meter in the same way. Precise FM tuning is also possible by adjusting so that the dial pointer of the upper meter is centered.

### TUNING KNOB

Rotate to tune in AM or FM broadcasts.

### MODE SWITCH

Selector switch for 2-channel and each type of four channel reproduction method.

**2CH:** During 2-channel stereo reproduction (sound does not emerge from rear speakers.)

**4CH CD-4:** For reproduction of discrete 4-channel tape, cartridge tape, or CD-4 records. 2-channel source can also be played in this position. At this time the same sounds are obtained from the rear left and right speakers as from the front left and right speakers (CH2 - CH1; CH4 - CH3).

**RM:** During 4-channel reproduction of Regular Matrix (RM) records and FM broadcasts. The matrix effect can also be obtained with a 2-channel program source.

**SQ:** For 4-channel reproduction of SQ system records and FM broadcasts. The matrix effect can also be obtained with a 2-channel program source.

**NOTE:** Sound will not be heard from the rear speakers (CH 2 & CH 4) at any setting of the Mode switch when the 2CH Power Boosting switch on the rear panel of the QX-949 has been set to 2CH.

### FM MUTING BUTTONS

Circuit for eliminating inter-station noise and weak interfering stations when tuning FM broadcast. Up position is ON; depress button (OFF) when weak station reception is desired.

### MPX NOISE FILTER BUTTON

Push this button to ON to eliminate high-frequency noise during FM stereo reception.

### FUNCTION SWITCH

Switch for selecting program source for playing.

**AM:** When listening to AM broadcasts

**FM MONO:** When listening to FM monophonic broadcasts

**FM AUTO:** Select when listening to FM stereo broadcasts. During FM monophonic broadcasts, automatically receives monophonic signals. Stereo indicator lights during FM stereo broadcasts.

**PHONO 1:** When playing records on turntable connected to the PHONO 1 terminals.

**PHONO 2:** Same as above for PHONO 2 terminals.

**AUX:** When playing component connected to the AUX terminals.

## BEFORE PLAYING

Before turning on the power switch, set the QX-949 as follows:

1. VOLUME control to minimum (counterclockwise).
2. All BALANCE controls to maximum (clockwise).
3. Front and rear BASS and TREBLE controls to center of rotation.
4. MODE switch to 4 CH CD-4.
5. FUNCTION switch to FM MONO.
6. TAPE MONITOR 2CH, 4CH-1, 4CH-2 and DOLBY NR ADAPTOR buttons should be in the up (OFF) positions.
7. FM MUTING button in the up (ON) position.
8. Depress SPEAKERS FRONT and REAR A buttons: (if B FRONT and REAR speakers are to be used, depress for the B position).
9. INDICATOR LEVEL buttons should be in the up (OFF) positions.

### CONFIRM PROPER CONNECTIONS

1. Set FUNCTION switch to FM MONO and MODE switch to 4 CH CD-4.
2. Depress POWER switch (ON), tune in FM station and adjust VOLUME control for normal listening level.
3. Turn all BALANCE controls completely counterclockwise (no sound will emanate from the speakers). **FRONT-LEFT (CH 1):** Rotate the FRONT-LEFT BALANCE control clockwise and confirm that sound emerges from the front-left speaker. Return the control to fully counterclockwise.

Repeat this procedure with each of the balance controls in turn and confirm that sound emerges from its corresponding speaker.

If sound does not come from a possibly loose-connected speaker, while the other speakers function normally, faulty speaker connection is indicated. Inspect the connection and wiring of that speaker and reconnect or rewire it if necessary.

### 4-CHANNEL BALANCE ADJUSTMENT

1. Turn all BALANCE controls completely clockwise (maximum).
2. Adjust VOLUME control for normal listening level.
3. Adjust the BALANCE controls to match the channel with the lowest volume.
  - If a second set of front and rear speakers (B) are connected, set the SPEAKER FRONT and REAR buttons to B (depressed) and perform the above two sections again before operating.



# FM AND AM BROADCASTS

## FM RECEPTION

1. Set the FUNCTION switch to FM AUTO.
2. Set the FM MUTING button to the up (ON) position, unless weak station reception is desired.
3. Select desired station by rotating the TUNING knob. Optimum reception is obtained when the pointer of the SIGNAL meter deflects to the extreme right, while the pointer of the TUNING meter indicates the center of the scale. Refer to Fig. 14.

The FM STEREO indicator lamp will light automatically when a stereo broadcast is tuned in. It will not light for a monophonic broadcast.

4. Set the MODE switch according to the type of broadcast, or personal preference.

Type of Broadcast	MODE Switch Setting
Regular Matrix (RM)	4 CH RM
SQ Matrix	4 CH SQ
Stereo *	2 CH, 4 CH CD-4, RM, SQ

\* Different settings of the MODE switch will produce various effects when listening to FM stereo broadcasts.

\* The 4-channel matrix effect cannot be obtained during FM monophonic broadcasts.

5. Adjust VOLUME control for comfortable listening; set BASS and TREBLE controls as desired.
- If the FM station is distant, or external noise objectionable, set the FUNCTION switch to FM MONO. This will reduce noise and provide more comfortable listening. In this case, even if FM stereo is being broadcast, reception will be monophonic.
  - If a high-frequency noise is heard during FM stereo reception, push the MPX NOISE FILTER button to eliminate such a noise.

## AM RECEPTION

1. Set FUNCTION switch to AM.
2. Select desired station by rotating the TUNING knob. Tune for maximum deflection of the SIGNAL meter toward the right. Refer to Fig. 15.
3. Set the MODE switch to 2CH. If sound is desired from all four speakers, set this switch to 4CH CD-4.
4. Adjust VOLUME, BASS and TREBLE controls for comfortable listening.

### NOTE:

If excessive noise occurs during AM or FM reception and cannot be cured by the above methods, re-read the section "Antenna and Ground Connections" (See p.7 ) for optimum reception.

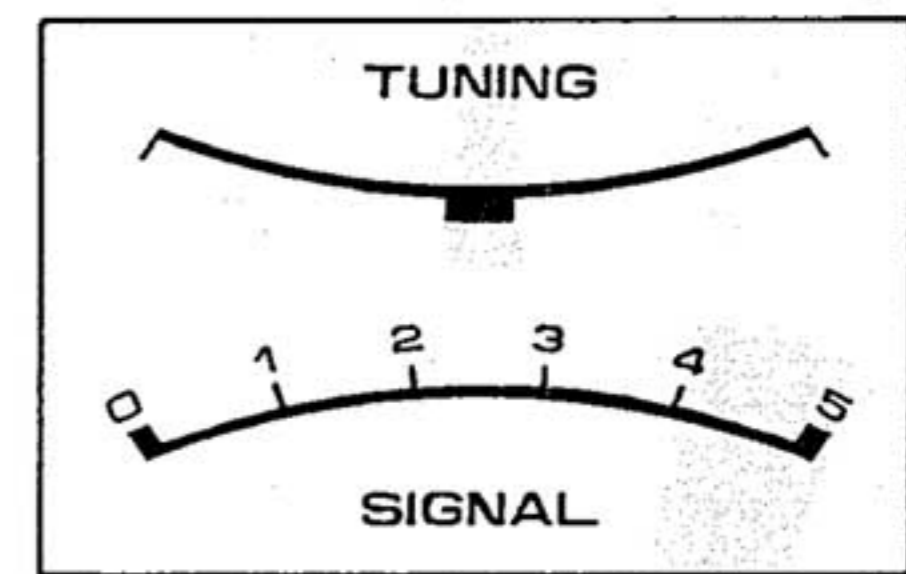

For FM reception

Fig. 14

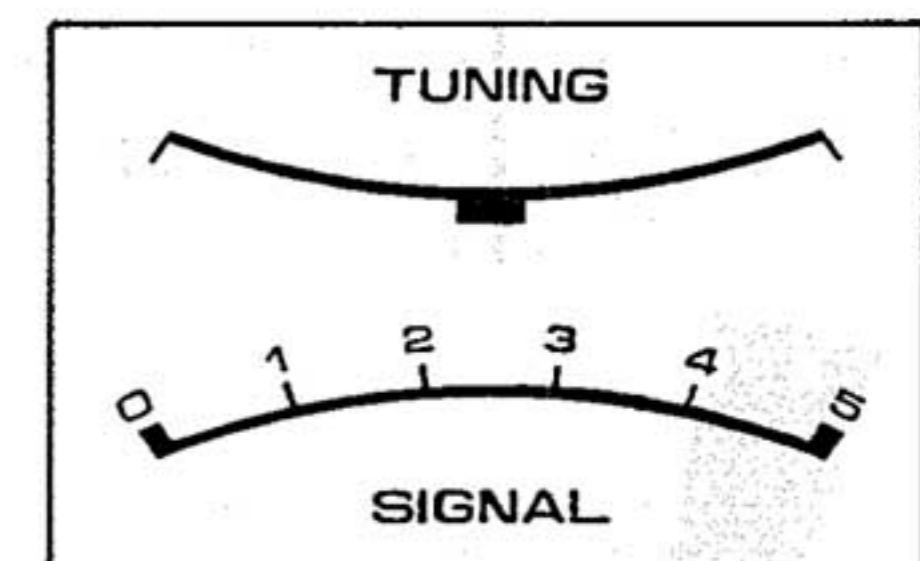

For AM reception

Fig. 15



# PLAYING CD-4 RECORDS

Refer to the "Before Playing" section on page 14, and confirm connections and adjustments.

1. Set the FUNCTION switch to PHONO 1. When records are played by the turntable connected to PHONO 2 terminals, set the FUNCTION switch to PHONO 2.
  2. Set the MODE switch to 4CH CD-4.
  3. Play a CD-4 record on the turntable.
  4. Set the VOLUME, BASS and TREBLE controls for comfortable listening.
- Be sure to use a CD-4 phono cartridge when playing CD-4 records.

## CD-4 RECORD PLAYING ADJUSTMENTS

### Carrier Level

1. Set the VOLUME control for normal listening level.
2. Play the "Carrier (30kHz) Level Signal" band 4 on the furnished CD-4 test record (Fig. 16).
3. While listening to the 400Hz signal, adjust the CARRIER LEVEL control of the QX-949 located on the front-right portion of the bottom panel. First set it to the fully clockwise position (maximum), then turn it counterclockwise a small amount at a time.
4. Stop turning at the point where the signal quality changes (distorts), then give it one or two turns clockwise from that point.

One adjustment of the CARRIER LEVEL control is sufficient. It need not be readjusted except after replacing the phono cartridge or stylus, and after an extended playing time.

### CD-4 Channel Separation Adjustment

Front (CH 1 & CH 3) and rear (CH 2 & CH 4) separation can be adjusted by the CD-4 Separation controls. Adjustment is performed so that rear volume is minimum while listening to test signal and observing 4 Channel Level Indicator, as shown in the diagrams.

1. Set the VOLUME control for normal listening level.
2. Rotate the BALANCE controls for all 4 channels fully clockwise. See Fig. 17(a).
3. Play the "Left Channel Separation Signal" band 1 on the test record.
4. While observing the rear left of 4-CHANNEL LEVEL INDICATOR, adjust the Left CD-4 SEPARATION control for minimum indication. Separation is then optimum. See Fig. 17(b).
5. Play the "Right Channel Separation Signal" band 2 on the test record.
6. While observing the rear right of 4-CHANNEL LEVEL INDICATOR, adjust the Right CD-4 SEPARATION control for minimum indication. Separation is then optimum. See Fig. 17(c).

**ASC (Automatic Selectivity Control) Circuit**  
When the engraved grooves of a CD-4 disc record are worn and a noise is heard, the ASC circuit suppresses such a noise by compensating for frequency in accordance with a change of carrier levels.

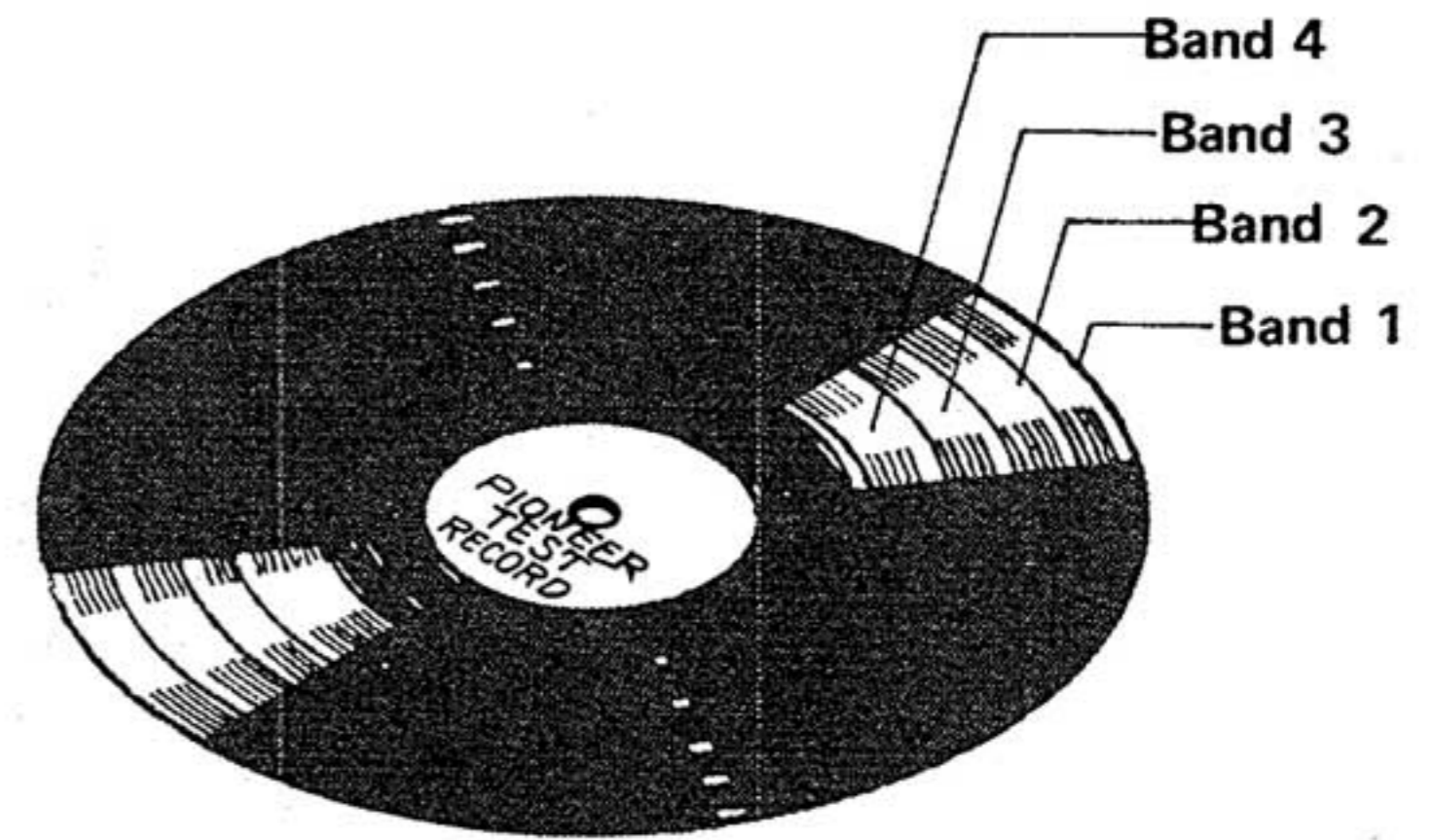

TEST RECORD (PQX-1011)

Fig. 16

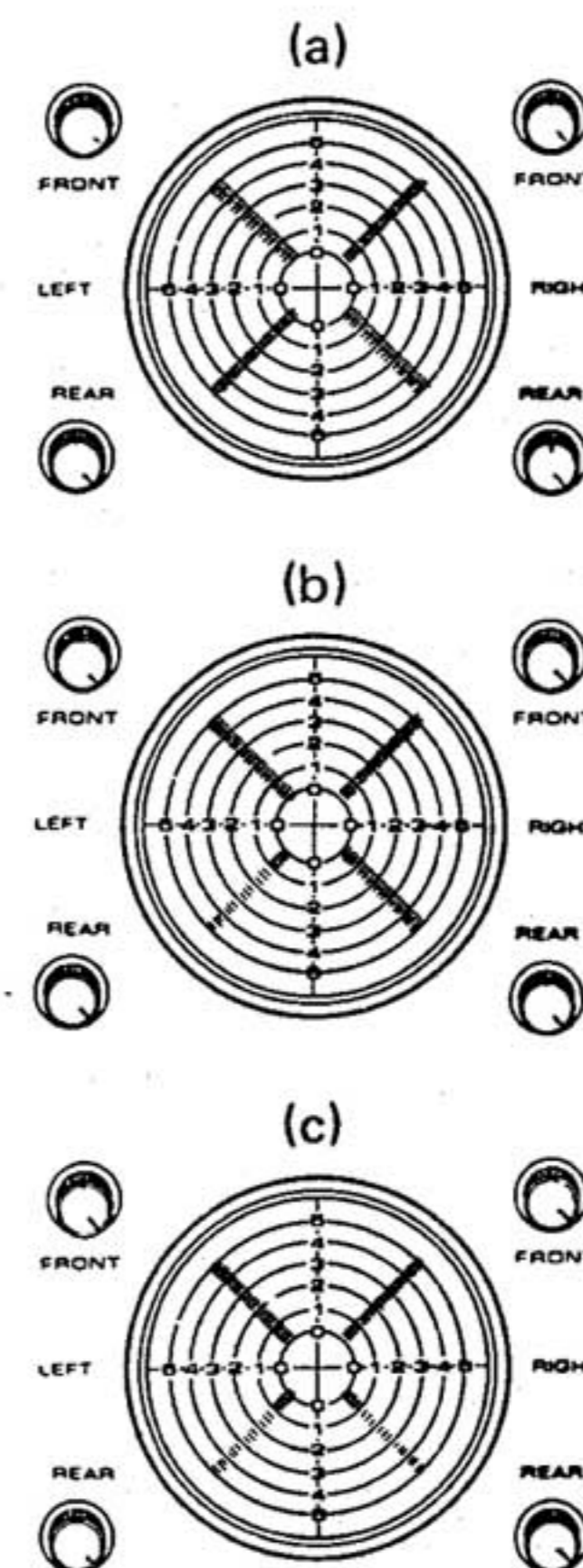

Fig. 17



## Channel Confirmation (Fig. 18)

1. Set the VOLUME control for normal listening level.
2. Play the "Channel Check" band 3 on the test record.
3. Confirm that sound emerges correctly from each connected speaker.
- If incorrect connection is discovered, reconnect. Then reperform the adjustment steps starting with the CD-4 Channel Separation Adjustment.

## Balance Adjustment

1. Set the VOLUME control for normal listening level.
2. Rotate the BALANCE controls of all channels fully clockwise.
3. Play the "Channel Check & Balance Adjustment" band 3 on the test record.
4. Adjust each channel BALANCE control while listening to the signal.

## Handling Records

Since CD-4 records employ finely cut grooves, accumulation of dust and dirt will generate noise, impair audio quality, and possibly damage the record surface. Proper reproduction also cannot be obtained if the record is warped. Records should be gently handled and carefully maintained.

Before and after playing, clean with a good quality record cleaner. Do not use sprays or wash with water.

## Stylus Cleaning

Dust or other foreign matter adhering to the stylus tip will impair audio quality and separation. Proper 4-channel reproduction may be lost and record possibly damaged. Always clean the stylus tip when playing records. If dirt is stubborn, an alcohol-based stylus cleaner, available from a high fidelity dealer, can be used to gently remove dirt.

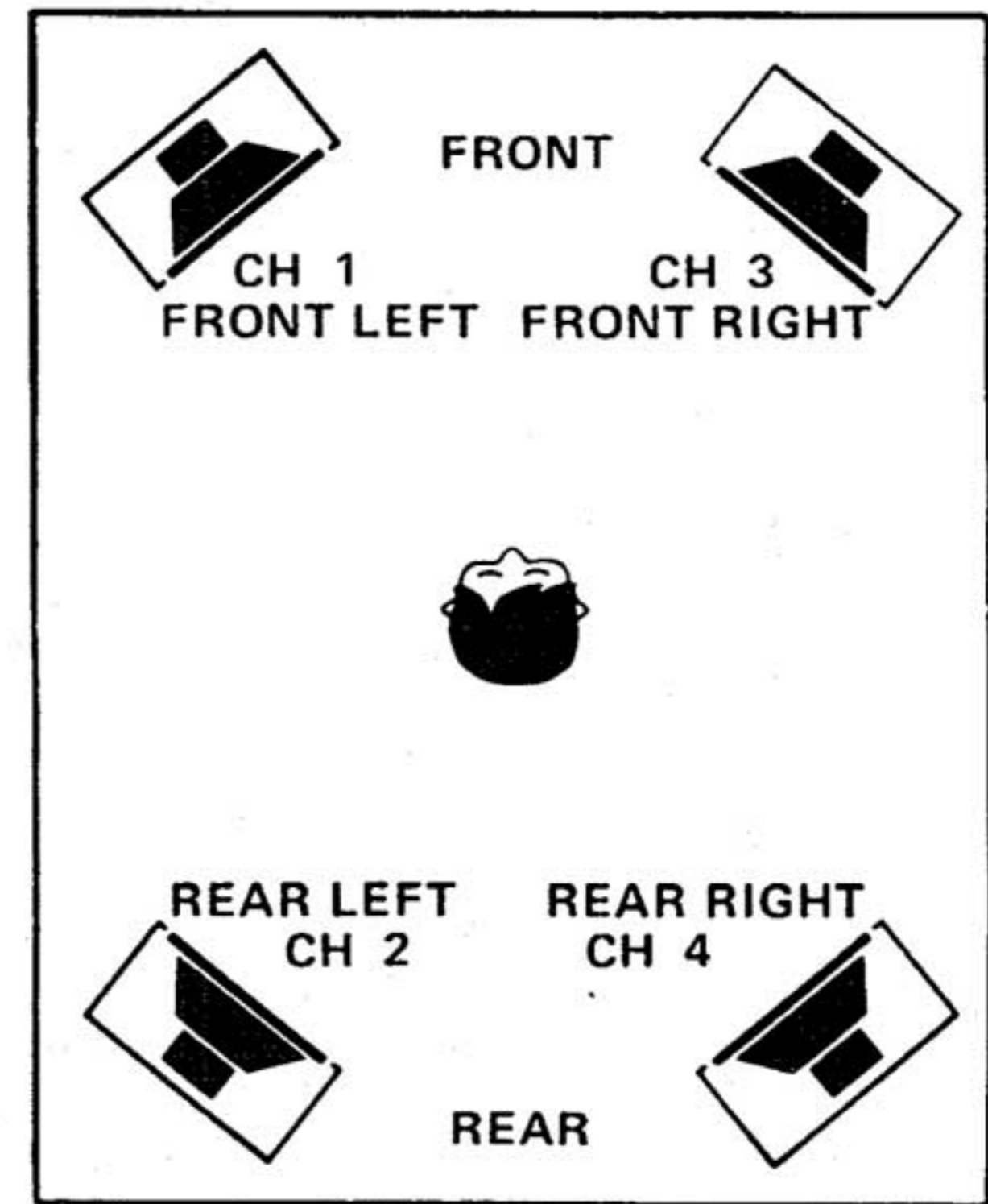

SPEAKER SYSTEM PLACEMENT Fig. 18

# PLAYING 2-CHANNEL AND MATRIX RECORDS

1. Set FUNCTION switch to PHONO 1. When records are played by turntable connected to PHONO 2 terminals, set the FUNCTION switch to PHONO 2.
2. Set MODE switch according to record type.
3. Play record on turntable.
4. Adjust VOLUME, BASS and TREBLE controls for comfortable listening.
- CD-4 phono cartridge may also be used for these records.

Record Type	MODE Switch Setting
Regular Matrix (RM)	4CH RM
SQ Matrix	4CH SQ
2-Channel or MONO*	2CH, 4CH CD-4

\* 4-channel effect can be obtained with MODE switch set to RM or SQ. If set to CD-4, rear sound will be equal to front sound.

\* When a CD-4 record adjusted for 4CH CD-4 is played with 2-channel phono cartridge employed, audio distortion may sometimes occur. In this case, set the CD-4 SEPARATION controls (Left & Right) counterclockwise.



# TAPE DECK OPERATION

## PLAYBACK

1. According to the TAPE terminals to which the tape deck is connected, depress the appropriate TAPE MONITOR 2CH, 4CH-1, 4CH-2 or DOLBY NR ADAPTOR button (Figs.19,20).
2. Operate tape deck for playback.
3. Adjust VOLUME, BASS and TREBLE controls for normal listening. When playing 2-channel tape with 2-channel tape deck connected to 2CH TAPE terminals, any playback effect you desire can be obtained by setting the MODE switch.

## RECORDING

**2-channel Tape Recording:** The program source selected by the FUNCTION switch appears at the 2CH TAPE REC terminals on the rear panel and is equal to the input signal(Fig. 21).

**4-channel Tape Recording:** The FUNCTION switch selected program source appears at the 4CH TAPE 1, 2 REC (DOLBY NR ADAPTOR OUT) terminals on the rear panel according to the MODE switch setting. Perform recording procedures according to the selected program source(Fig. 22).

### Tape Monitor

If the TAPE MONITOR button of the QX-949 is set to ON, the recording condition can be monitored from the speakers. In this case, a 3-head type tape deck or deck equipped with monitor function must be employed. Connection must be performed for recording and playback.

### WHEN DUPLICATING OR EDITING RECORDED TAPE

Duplication of recorded tape from playback deck to recording deck can be performed by persons owning two tape decks.

#### Duplicating 4-Channel Recorded Tape

Perform the following steps with two 4-channel tape decks.

1. As shown in Fig. 23, connect the playback 4-channel tape deck to the 4CH TAPE 1 terminals and the recording 4-channel tape deck to the 4CH TAPE 2 terminals. Refer to the section on Tape Deck Connection for connecting method. See page 9.
2. Set the TAPE MONITOR 4CH-1 button to ON and play recorded tape.
3. Record with the tape deck connected to the 4CH TAPE 2 terminals.

If the TAPE MONITOR 4CH-2 button is operated ON-OFF during recording, recording conditions can be monitored.

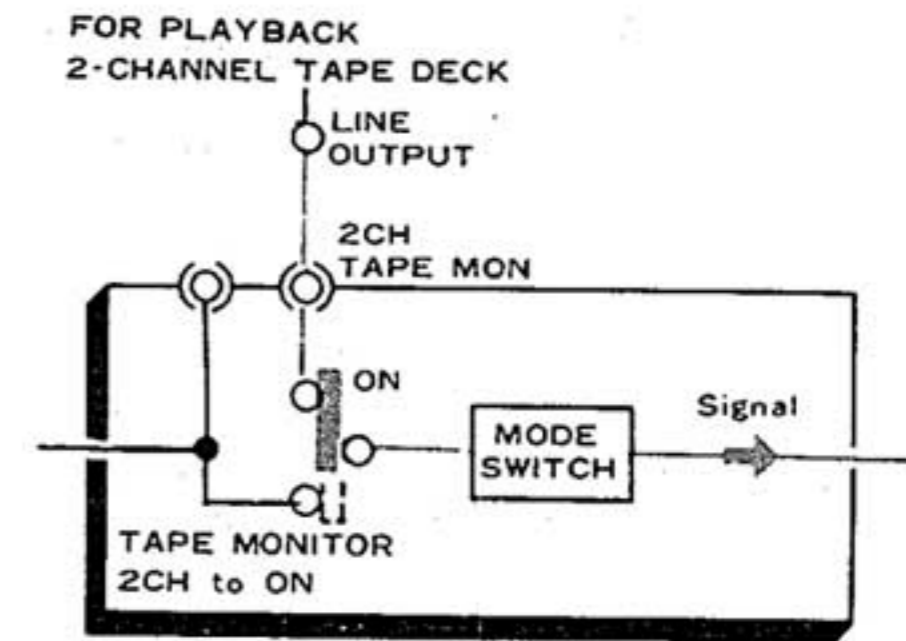

Fig. 19

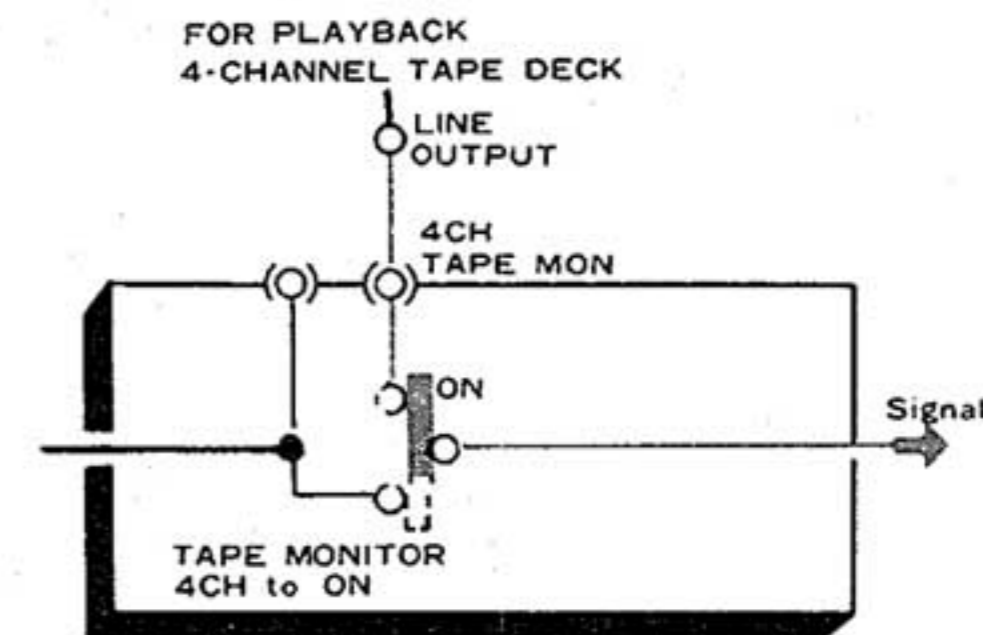

Fig. 20

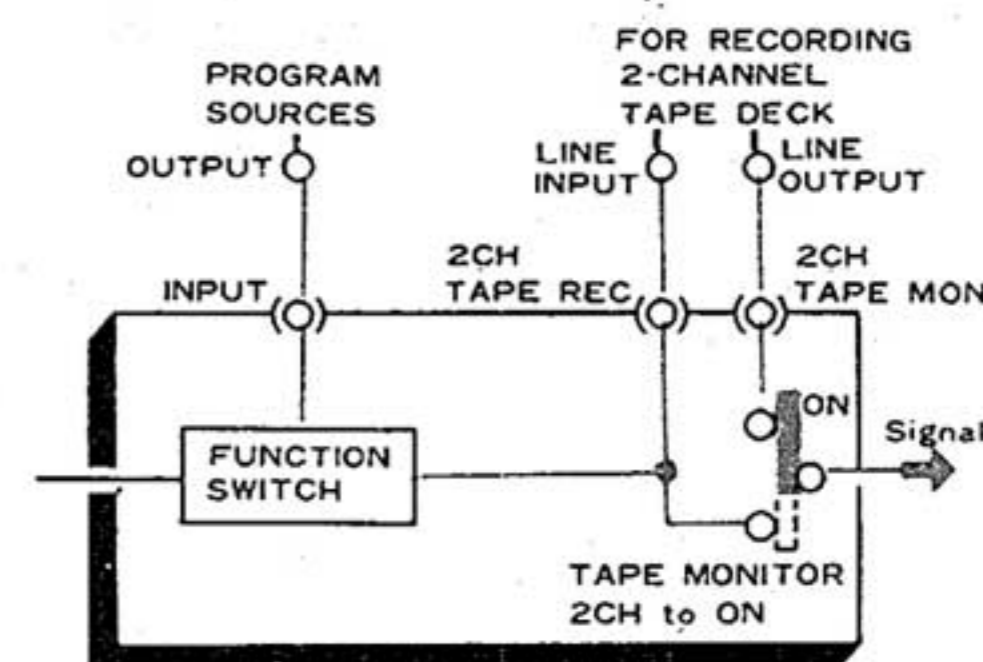

Fig. 21

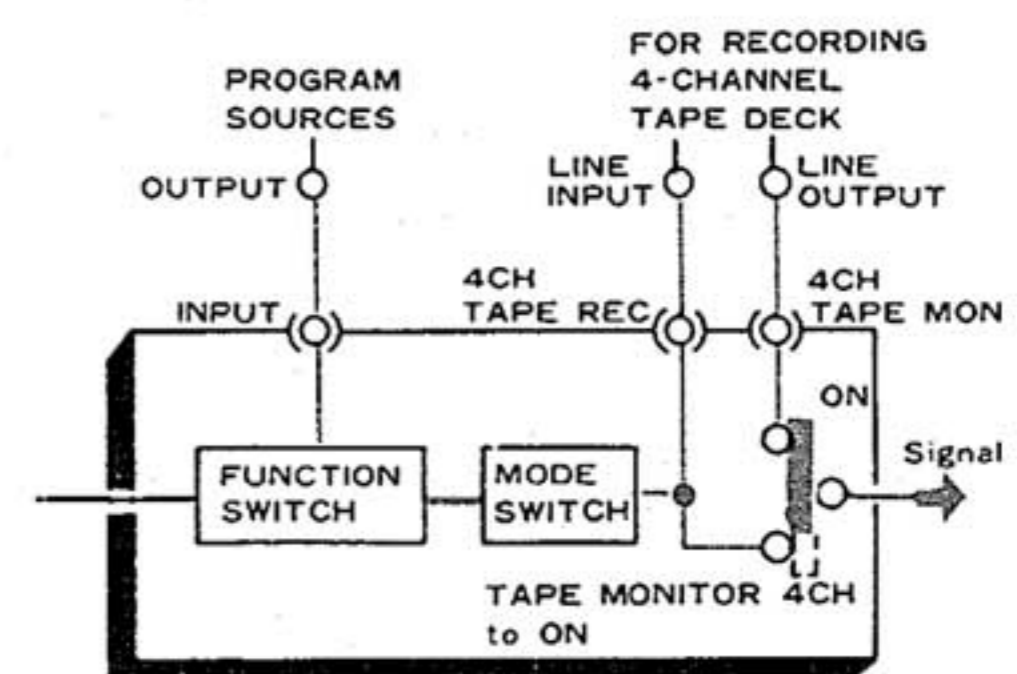

Fig. 22

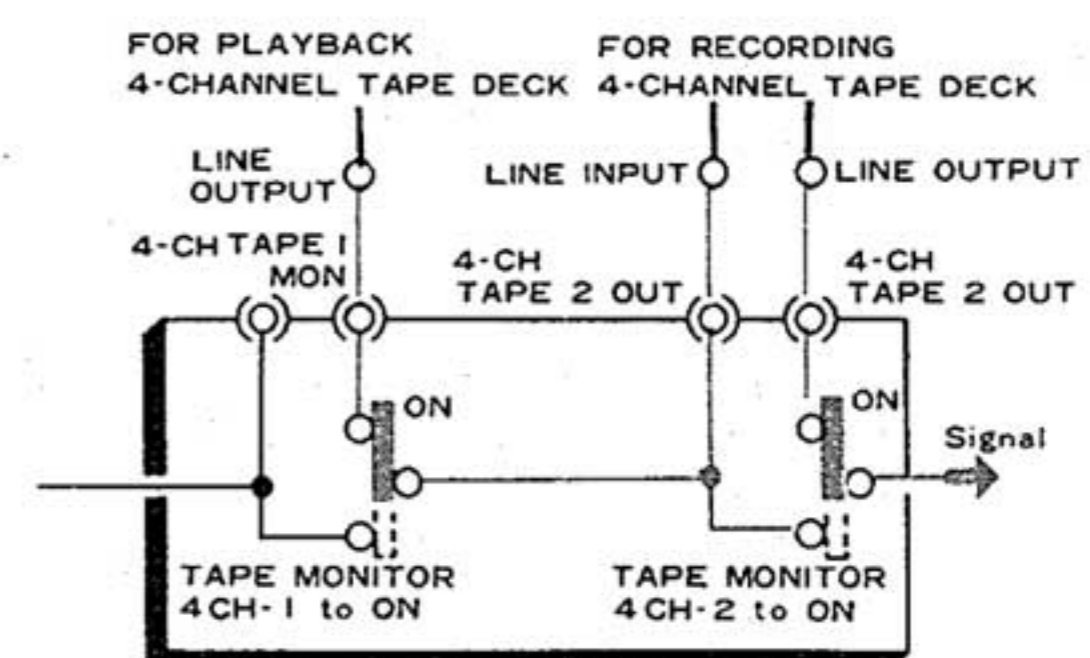

Fig. 23



When editing 2-channel recorded tape onto 4-channel tape.

Operate 2-channel and 4-channel tape decks as follows.

1. As shown in Fig.24, connect the 2-channel tape deck for playback to the 2CH TAPE terminals and the 4-channel tape deck for recording to the 4CH TAPE 1 terminals. Refer to the section on Tape Deck Connection for connecting method. See page 9.
2. Set the TAPE MONITOR 2CH button to ON and play the recorded tape.
3. Set the MODE switch to desired mode (4CH CD-4, RM, SQ).
4. Record with the tape deck connected to the 4CH TAPE 1 terminals.  
If the TAPE MONITOR 4CH-1 button is operated ON-OFF during recording, recording conditions can be monitored.

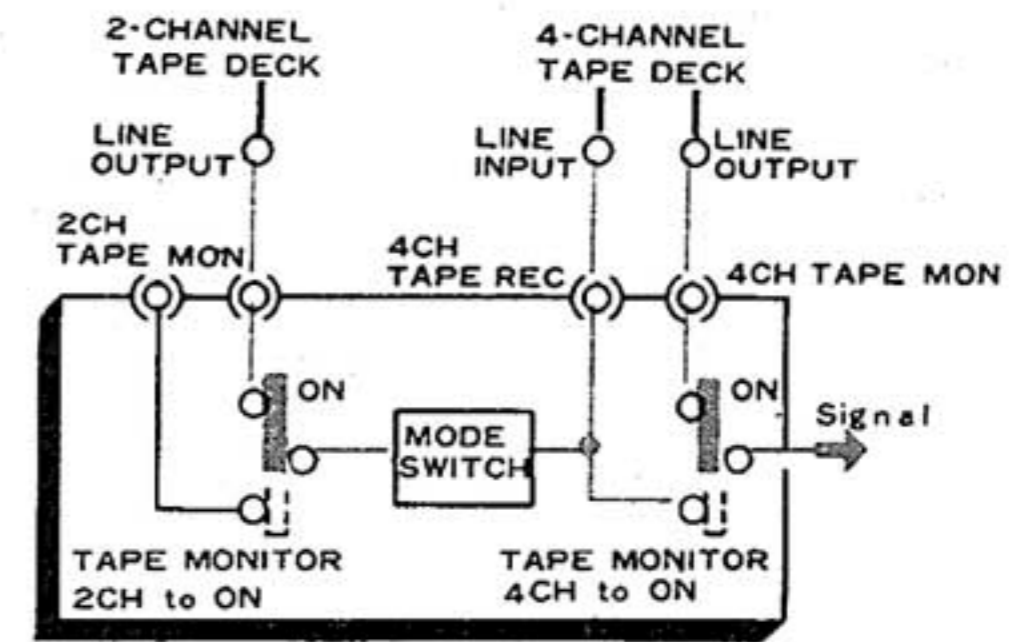

Fig. 24

## EMPLOYING DOLBY NR ADAPTOR TERMINALS

Connect Dolby adaptor to the DOLBY NR ADAPTOR terminals of the QX-949. FM Dolby broadcast reproduction, and by connecting a tape deck to the Dolby adaptor, Dolby recording and playback can be performed.

### FM DOLBY REPRODUCTION

When receiving FM Dolby broadcast signals, perform the following connectins for Dolby reproduction.

1. As illustrated in Fig. 25, connect Dolby adaptor to the DOLBY NR ADAPTOR terminals.
2. Set the FUNCTION switch to FM AUTO and the DOLBY button to ON, then tune in Dolby FM station.
3. Set the MODE switch to 2CH. In this situation, only the front signals (CH1 & CH3) will be obtained.

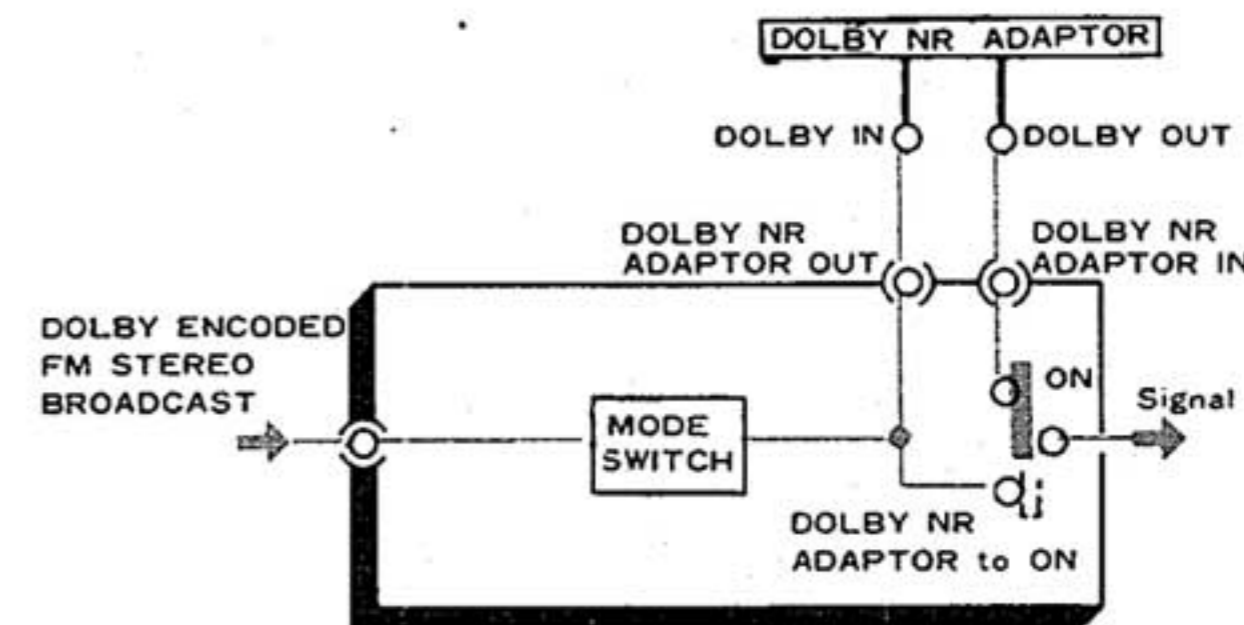

Fig. 25

### DOLBY TAPE RECORDING

1. As shown in Fig. 26, connect Dolby adaptor output to tape deck recording input (line input) terminals.
2. Set FUNCTION and MODE switches according to program source, and proceed with recording.
- Set the DOLBY NR ADAPTOR button of the QX-949 to ON to monitor Dolby source during record.

### DOLBY TAPE PLAYBACK

1. Connect tape deck output (line output) terminals to Dolby adaptor input terminals.
2. Turn on the DOLBY NR ADAPTOR button. Dolby recorded tapes may then be played.

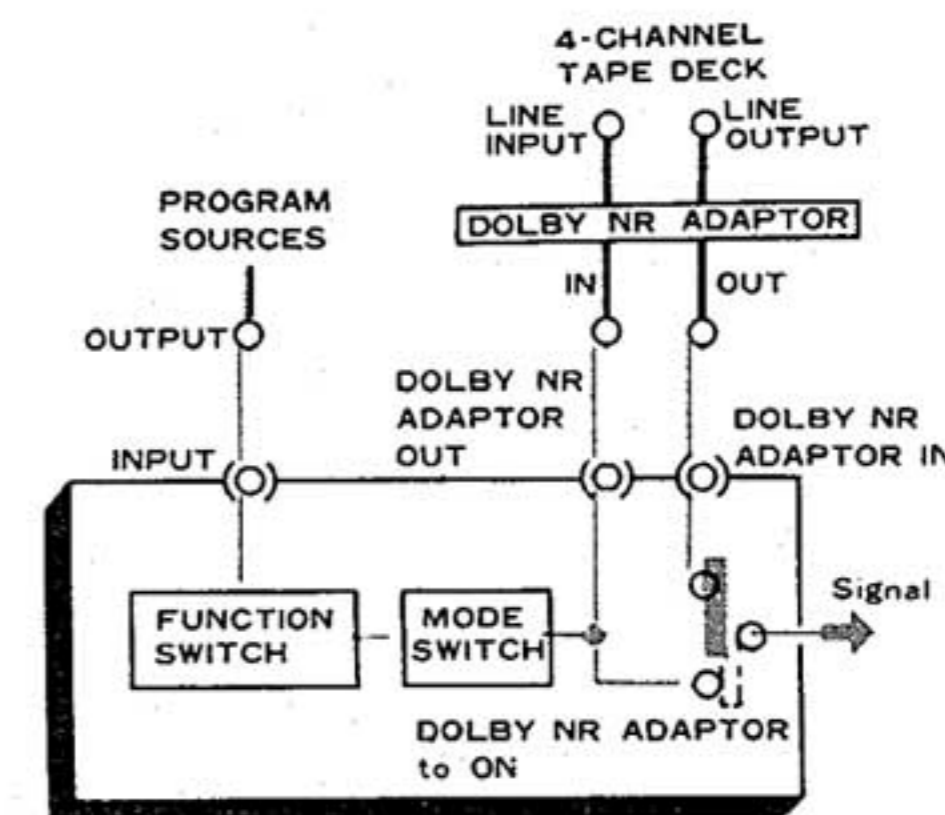

Fig. 26

#### NOTE:

Refer to the Dolby adaptor instructions for detailed information regarding its operation.



# USING THE AUX TERMINALS

Employ the following procedure when playing components connected to the AUX terminals.

1. Set the FUNCTION switch to AUX.
2. Position MODE switch according to program source.
3. Operate component.
4. Adjust VOLUME, BASS and TREBLE controls for desired listening.

## 4CH MPX OUTPUT TERMINAL

This terminal is used when receiving 4-channel discrete FM broadcasts.

1. Connect 4CH MPX OUTPUT terminal to 4-channel discrete FM adaptor.
2. Connect FM adaptor output terminal to 4CH TAPE 1 MON terminal.
3. Set the TAPE MONITOR 4CH-1 button to ON.
4. Set FUNCTION switch to FM AUTO.
5. 4-channel discrete FM broadcasts can then be received.

**NOTE:**

Refer to adaptor instructions for detailed operating information.

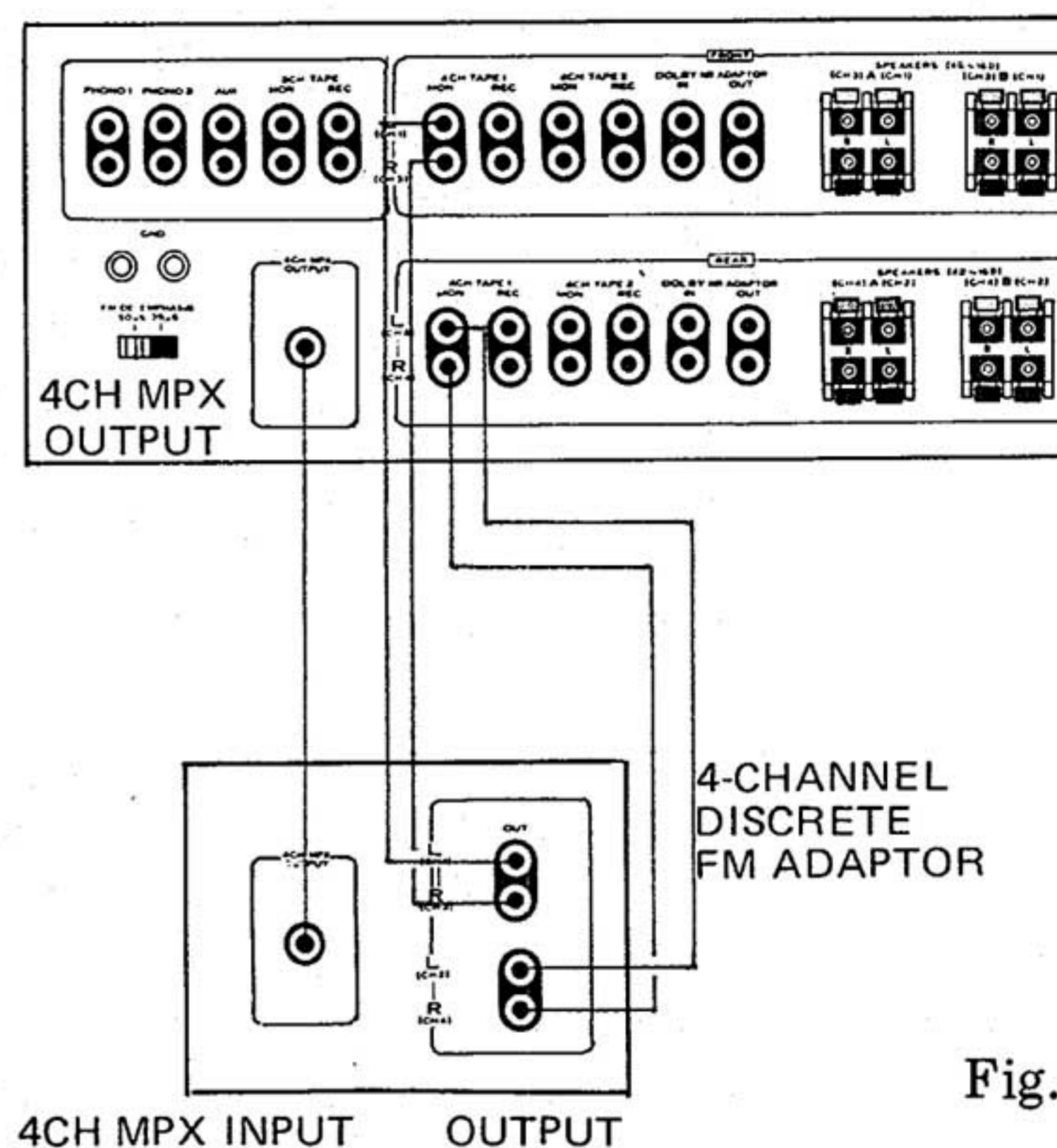

Fig. 27



# CONDITIONS FREQUENTLY MISTAKEN FOR MALFUNCTION

Noise: There are a variety of noises relating to the operation of a hi-fi unit. These are generally divided into two types; (1) the unit is faulty (a transistor or part has deteriorated) and (2) an external source is adding to the unit.

When a hi-fi unit produces an unpleasant noise, it is often assumed that the unit is faulty, but statistical records indicate that the majority of noises pro-

duced in hi-fi acoustic units result from external sources of noise: Due to the inherent high sensitivity and the high fidelity in reproduction, the unit amplifies and reproduces extraneous noises, however small, into definite output noise. If your receiver produces a noise, check according to the following table and trace out the source of noise for the appropriate corrective action.

	SYMPTOM	SUSPECTED SOURCE OF NOISE	DIAGNOSIS AND REMEDY
WHEN LISTENING TO BROADCASTS	Continuous or intermittent noise like jjjjjj or zzzzzz.	<ul style="list-style-type: none"> <li>• Static (lightning)</li> <li>• Fluorescent lamp, motor, or thermostat may be in use in house or in the vicinity of the house.</li> </ul>	In many cases, it is very difficult to remove the source of noise. In order to make the radio input larger than the noise level, set up a good outdoor antenna and make a complete grounding.
	When a station is tuned in, hum is mixed in the program.	<ul style="list-style-type: none"> <li>• Poor fluorescent lamp, motor, or electric heater may be in use in house or near the house.</li> </ul>	Reversing the line plug may occasionally alleviate this noise problem. Usually it is very difficult to eliminate the noise.
	Hissing sound noise in AM (medium wave) reception.	<ul style="list-style-type: none"> <li>• The frequency of an adjacent station is interfering with that of the station being tuned in (10kHz beat interference).</li> <li>• TV set is on in the same house with the receiver.</li> </ul>	Impossible to remove such interference. If the case of such noise is in the TV set, increase the distance between the TV set and receiver.
	Static noise (in particular, when automobiles run close to the house).	<ul style="list-style-type: none"> <li>• While noise is generated from automobile engines.</li> <li>• High frequency sewing machine or welding machine being used near your house.</li> </ul>	In an area surrounded by hills or high buildings, the FM input signals are very weak. Thus the noise limiter in the circuit loses its function. Set up an outdoor FM antenna having many director elements.
	Reception of FM stereo program contains more noise than FM mono program.	<ul style="list-style-type: none"> <li>• Note that the service area covered by an FM stereo broadcast is about 50% of that of a regular mono broadcast.</li> </ul>	Increasing FM input signal may alleviate this problem. Use an exclusive outdoor FM antenna instead of the indoor T-type antenna.
WHEN PLAYING RECORDS	Hum or buzz. When switched to radio reception, the noise disappears.	<ul style="list-style-type: none"> <li>• Poor connection of shielded wire. (a)</li> <li>• Jack connection is loose. (b)</li> <li>• Line cord of fluorescent lamp is near the shielded wire. (c)</li> <li>• Poor grounding. (d)</li> <li>• Ham transmitting station or TV transmitting station is near your house. (e)</li> </ul>	Correct the conditions stated in (a), (b), (c) or (d). In case of (e), report it to an official activity.
	Output tone quality is poor and mixed with noise. Treble is not clear.	<ul style="list-style-type: none"> <li>• Stylus wears out. (a)</li> <li>• Record wears out. (b)</li> <li>• Dust adheres to stylus. (c)</li> <li>• Stylus is improperly mounted. (d)</li> <li>• Stylus pressure is not proper. (e)</li> <li>• The TREBLE level is too high. (f)</li> <li>• 2-channel phono cartridge used; Mode switch set to 4CH CD-4. (g)</li> </ul>	Check (a) through (e) and correct the condition. Lower the TREBLE level. (f) Set Mode switch to 2 CH, RM, or SQ. (g)

## WATCH FOR THE FOLLOWING CONDITIONS; THESE ARE ALSO APT TO BE MISTAKEN FOR MALFUNCTION

	SYMPTOM	SUSPECTED SOURCE OF NOISE	DIAGNOSIS AND REMEDY
	Power is not turned on although the power switch is set to ON.	<ul style="list-style-type: none"> <li>• Fuse blows. (a)</li> <li>• Line plug is loose. (b)</li> <li>• 2CH Power boosting switch not properly installed.</li> </ul>	Check (a) and (b) and correct the condition.  Inspect.
	4-channel not obtained at any Mode switch setting.	<ul style="list-style-type: none"> <li>• 2CH Power boosting switch set to 2CH.</li> </ul>	Set to 4 CH.
	In playing a record, increasing the volume causes howling.	<ul style="list-style-type: none"> <li>• Distance between the turntable and the speakers is too short.</li> <li>• The place on which the turntable or speakers are set is unstable.</li> </ul>	Change the distance or rearrange the installation increase of the unit and speakers. (Installing the turntable on a firm, solid stand may alleviate this problem.) Do not enhance the BASS sound level excessively.



# CD-4 TECHNICAL OUTLINE

Conventional two-channel stereo records employ a V-shaped groove in which the left and right sounds are recorded on the left and right groove walls respectively. If four-channel recordings are to be produced by this method, the left-right-front-rear sounds must first be converted from 4 sounds into two sounds before the grooves are cut. This approach is termed matrix 4-channel.

CD-4 records utilize two types of signals (Fig. 28) which are cut into the left and right groove walls. One of these signals consists of ordinary audible frequencies of less than 15kHz, which are cut in the same way as conventional records. The other signal is comprised of frequencies above 20kHz, which the human ear cannot hear. It is FM modulated on a 30kHz carrier signal and has a frequency band of 20kHz to 45kHz. This is also engraved on the record.

If the stylus were to trace the sound groove represented by the central A portion of the diagram, audible sound can be directly reproduced. The B sound, contained in the X signal, can be extracted from the X signal by using a demodulator and returned to an audible signal.

Actual CD-4 records, as indicated in Fig. 29, divide the directly audible sounds into A and C, A is left front and rear, C is right front and rear. The mixed signals provide compatibility which allows reproduction of 2-channel audio by two-channel equipment.

On the other hand, signals B and D consist of front, rear, right, left sound difference components only. Thus, when reproduced with truly four-channel equipment, the A, B, C and D sounds are separated into independent four-channel signals (front left, front right, rear left, rear right) by the demodulator and matrix circuits and applied to the amplifier (Fig. 29).

As discussed in the foregoing, the signals cut into CD-4 record grooves are considerably more complex than those of conventional records. It thus becomes important to employ the proper cartridge and tracking force during reproduction and to keep the record grooves and stylus free from dust.

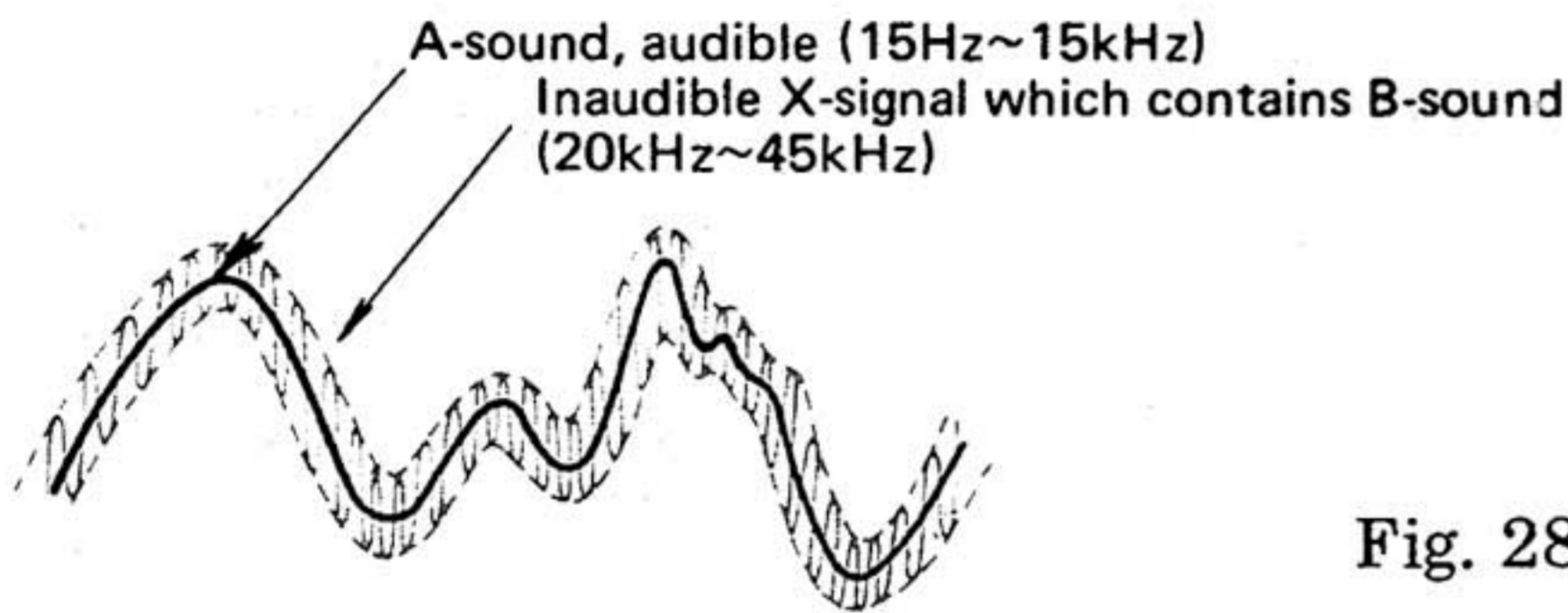

Fig. 28

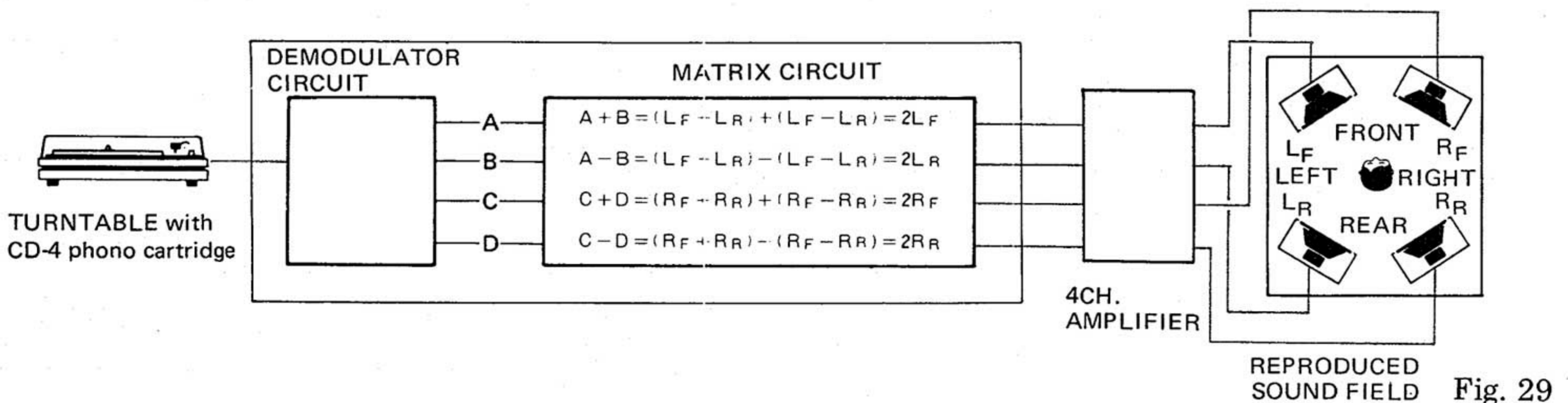
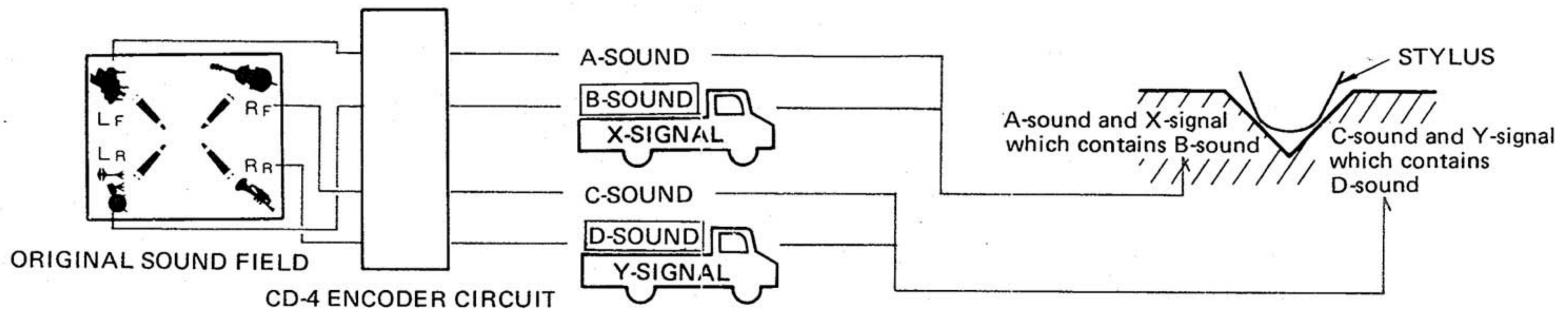

Fig. 29



# MATRIX 4-CHANNEL RECORDS

There are two principle types of matrix 4-channel systems: regular matrix (RM) and SQ matrix. Both types of records are on the market and broadcast by FM stereo stations. Regular matrix and SQ matrix are not mutually compatible and each requires a different type of decoder for four-channel reproduction.

## REGULAR MATRIX (RM)

Regular matrix 4-channel records (and FM broadcasts), as depicted in Fig. 30, employ a phase shifter for separating the four-channel signals from the  $L_T$  &  $R_T$  signals. As can be understood from the diagram,  $\alpha$  component of signal  $R_T$  is added to signal  $L_T$  to form front left signal  $L_F$ , while the  $\alpha$  component of signal  $L_T$  is added to signal  $R_T$  to form front right signal  $R_F$ .

Signal  $L_R$  (rear left) is formed by combining the  $\beta$  component of the  $90^\circ$  phase advanced  $R_T$  signal ( $+R_T$ ) to the  $90^\circ$  phase delayed  $L_T$  signal ( $-jL_T$ ) from the phase shifter. The  $R_R$  signal (rear right) is composed by blending the  $\beta$  component of the  $-jL_T$  signal with the above mentioned  $+jR_T$  signal.

$$\begin{aligned} L_F \text{ (front left/CH 1)} &= L_T + \alpha R_T \\ R_F \text{ (front right/CH 3)} &= R_T + \alpha L_T \\ L_R \text{ (rear left/CH 2)} &= -jL_T + j\beta R_T \\ R_R \text{ (rear right/CH 4)} &= +jR_T - j\beta L_T \end{aligned}$$

This also permits matrix reproduction of two-channel records or FM broadcasts with a pleasant effect that is different from 2-channel sound.

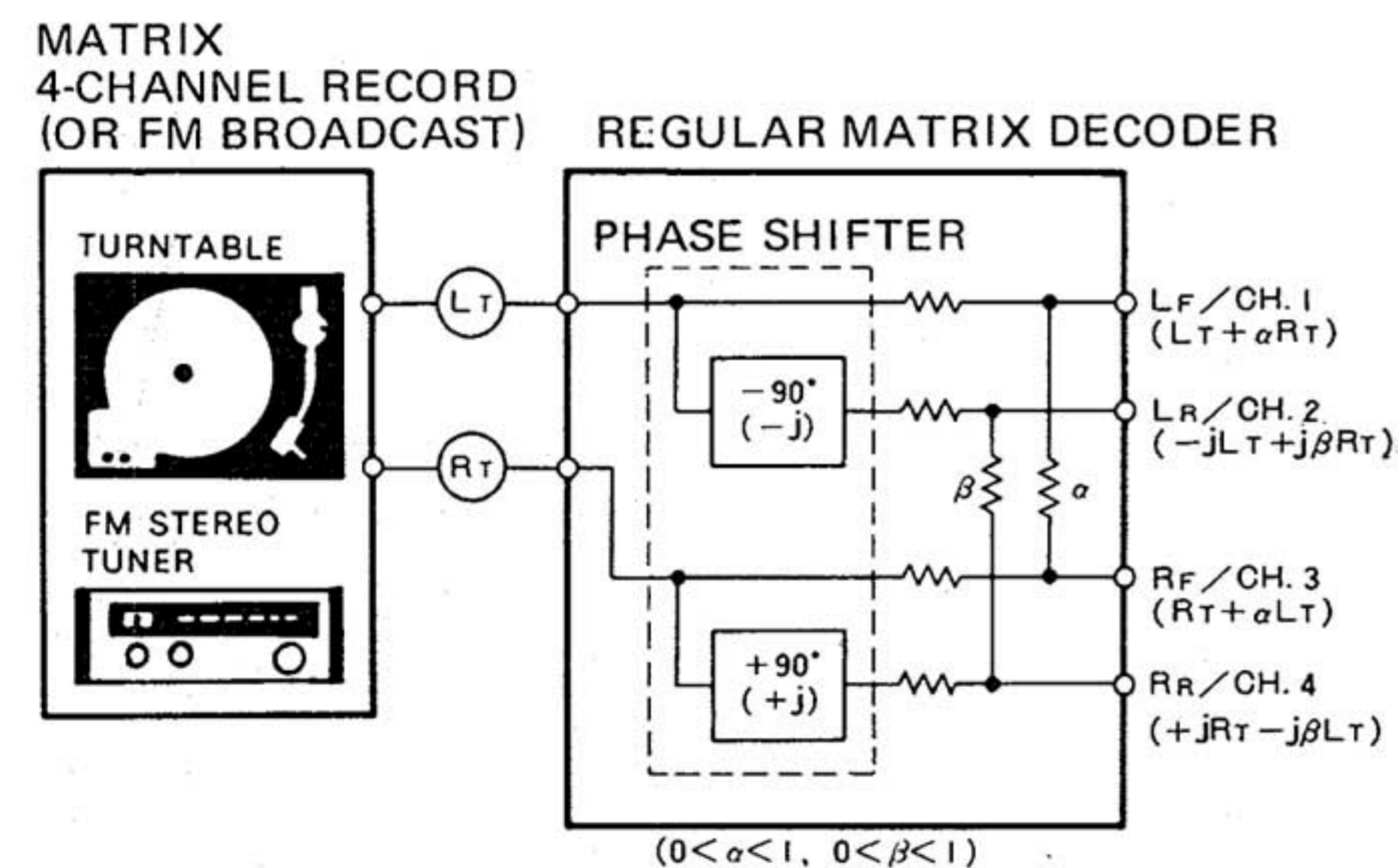

Fig. 30

## SQ MATRIX

As illustrated in Fig. 31, the signal from SQ matrix records or FM broadcasts ( $L_T$  &  $R_T$ ) is applied to a phase shifter for separating the four channels. It can be understood from the diagram that the  $L_T$  and  $R_T$  signals directly become the  $L_F$  (CH 1) and  $R_F$  (CH 3) signals respectively. Therefore, the  $R_F$  ( $L_F$ ) signal components cannot be applied to the  $L_F$  ( $R_F$ ).

On the other hand, the  $R_T$  signal is blended with the  $L_T$  signal which has been delayed in phase  $90^\circ$  by the phase shifter. The signal is then attenuated  $1/\sqrt{2} \approx 0.7$  after which the phase is again reversed ( $180^\circ$ ) to become  $L_R$  (CH 2). Signal  $L_T$  is also blended with the  $90^\circ$  phase delayed signal  $R_T$ , then attenuated  $1/\sqrt{2} \approx 0.7$  to produce the  $R_R$  (CH 4) signal.

$$\begin{aligned} L_F \text{ (CH 1)} &= L_T \\ R_F \text{ (CH 3)} &= R_T \\ L_F \text{ (CH 2)} &= +j0.7L_T - 0.7R_T \\ R_R \text{ (CH 4)} &= -j0.7R_T + 0.7L_T \end{aligned}$$

In this manner, the separation between  $L_F$  and  $R_F$  can be said to be better in the SQ system than in the regular matrix method.

During the matrix reproduction of 2-channel records or FM broadcasts, the separation between  $L_F$  and  $R_F$  becomes theoretically infinite. The  $90^\circ$  phase difference of the rear signals ( $L_R$  &  $R_R$ ) results in a pleasant depth effect resembling a concert hall.

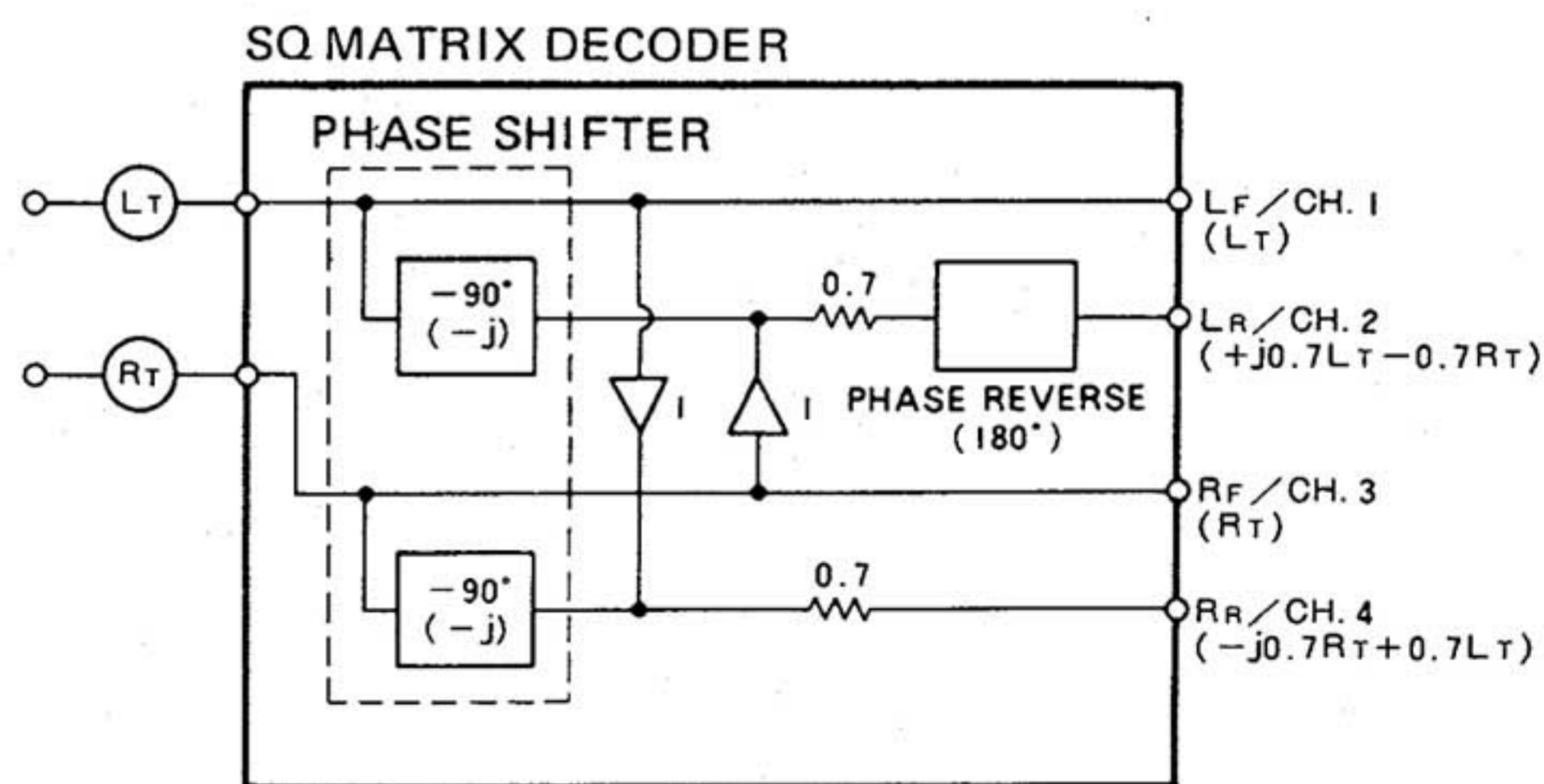

Fig. 31



## Semiconductors

FETs	14	Transistors	117
ICs	7	Diodes	69

## Amplifier Section

Circuitry . . . . . Direct Coupled Complementary OCL

### Continuous Power Output

20Hz~20kHz (4 channels driven)	40W x 4 (8Ω), 50W x 4 (4Ω)
1kHz (4 channels driven)	44W x 4 (8Ω), 58W x 4 (4Ω)
1kHz (Each channel driven)	53W/CH (8Ω), 75W/CH (4Ω)

### Continuous Power Output

(2CH. POWER BOOSTING SWITCH set at "2 CH")

20Hz~20kHz	
(2 channels driven)	60W+60W (8Ω), 75W+75W (4Ω)
1kHz (2 channels driven)	65W+65W (8Ω), 85W+85W (4Ω)
1kHz (Each channel driven)	75W/CH (8Ω), 100W/CH (4Ω)

### Harmonic Distortion

(Continuous Power Output)	Less than 0.3%
(1W x 4, Power Output)	Less than 0.05%

### Intermodulation Distortion

(Continuous Power Output)	Less than 0.3%
(1W x 4, Power Output)	Less than 0.05%

### Power Bandwidth

(IHF, 4 channels driven)	7Hz~40kHz
--------------------------	-----------

### Output

Speaker	FRONT: A, B, A+B (4~16Ω) REAR: A, B, A+B
---------	---

Headphones . . . . . FRONT & REAR

Damping Factor (1kHz, 8Ω) . . . . . More than 35

### Residual Hum & Noise

(8Ω, Pre & Power Amplifier)	Less than 1mV
-----------------------------	---------------

### Input Sensitivity/Impedance

PHONO 1	2.5mV/50kΩ
PHONO 2	2.5mV/50kΩ
PHONO Overload Level (rms/p-p)	100mV/280mV
AUX	150mV/100kΩ
TAPE MONITOR (2CH, 4CH)	150mV/100kΩ

### Output Level/Impedance

TAPE REC (2CH, 4CH)	150mV
---------------------	-------

### Frequency Response

PHONO (RIAA equalization)	30Hz~15kHz±1dB
AUX, TAPE MON	7Hz~25kHz $^{+0.5}_{-1}$ dB

### Tone Control

BASS	±10dB (100Hz)
TREBLE	±10dB (10kHz)

### Filter

LOW	50Hz (6dB/oct.)
HIGH	10kHz (6dB/oct.)

### Loudness Contour

(Volume control set at -40dB position) +6dB(100Hz), +3dB(10kHz)

### Hum & Noise (IHF, Short-circuited, A Network)

PHONO	More than 70dB
AUX, TAPE MON	More than 90dB



## CD-4 Demodulator Section

Input Sensitivity	2.5mV (1~5mV adjustable)
Input Impedance	100kΩ
Harmonic Distortion	0.07%
Signal-to-Noise Ratio (IHF, A Network)	More than 70dB
Separation (STD Test Signal at 1kHz)	
Left ~ Right	50dB
Front ~ Rear	30dB
Frequency Response	20Hz~15kHz

## FM Tuner Section

Circuitry	2 MOS FETs, 1-stage RF Amplifier, 4-ganged Tuning Capacitor, 6-stage Limiter
Usable Sensitivity (IHF)	1.8μF
Capture Ratio (IHF)	1dB
Selectivity (IHF)	80dB
Signal-to-Noise Ratio	70dB
Image Rejection (98MHz)	More than 85dB
IF Rejection (98MHz)	More than 100dB
Spurious Rejection	More than 100dB
AM Suppression	55dB
Harmonic Distortion	
Mono	Less than 0.2%
Stereo	Less than 0.4%
Frequency Response	20Hz~15kHz $\pm 0.2$ dB 50Hz~10kHz $\pm 0.5$ dB

## Stereo Separation

1kHz	More than 40dB
50Hz~10kHz	More than 30dB
Sub-carrier Suppression	65dB
Antenna Input	300Ω Balanced, 75Ω Unbalanced
Muting	ON-OFF
MPX Noise Filter	ON-OFF

## AM Section

Circuitry	1 Stage RF Amplifier, 3-ganged Tuning Capacitor
Sensitivity	
(IHF, Ferrite Antenna)	300μV/m
(IHF, Ext. Antenna)	15μV
Selectivity	40dB
Signal-to-Noise Ratio	50dB
Image Rejection	More than 65dB
IF Rejection	More than 85dB
Antenna	Built-in Ferrite Loopstick Antenna

## Miscellaneous

Built-in CD-4 Demodulator, Regular Matrix Decoder, SQ Matrix Decoder	
Power Requirements	AC 120V 60Hz or 110, 120V, 130V, 220V and 240V (Switchable) 50/60Hz
Power Consumption	250W (UL approved model only) 530W (5-line Voltage model only)
AC Outlets	Unswitched 2, Switched 1
Dimensions	550(W) x 160(H) x 440(D)mm 22-1/16 x 6-5/16 x 17-5/16 in.
Weight: Without Package	22.4kg 49 lb 5oz
With Package	27.2kg 59 lb 14oz

## Furnished Parts

FM T-type Antenna	1
CD-4 Test Record (PQX-1011)	1
Operating Instructions	1

## POWER CONSUMPTION NEWLY MEASURED ON A CSA STANDARD BASIS

The QX-949, whose specification conforms to UL standard by which all technical data concerned were measured and described here, has been recently qualified by CSA standard. Therefore, of the already-described specifications on page 25, only the power consumption was newly measured on a CSA standard basis and the corresponding description was changed to 400W/450VA from 250W.

Please note, however, that substantial power consumption is quite the same as before. This illustration shows Fuse Cap of Connection Diagram on page 11.

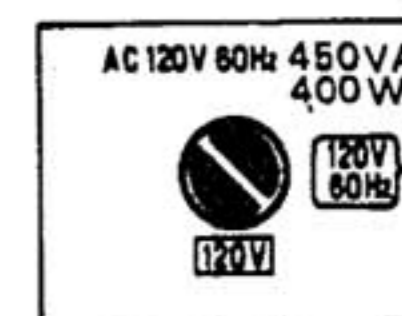

After Changing

**NOTE:**  
Specifications and the design subject to possible modification without notice due to improvements.



**PIONEER ELECTRONIC CORPORATION**

4-1, 1-Chome, Meguro, Meguro-ku, Tokyo 153, Japan

**U.S. PIONEER ELECTRONICS CORPORATION**

178 Commerce Road, Carlstadt, New Jersey 07072, U.S.A.

**PIONEER ELECTRONIC (EUROPE) N.V.**

Meir-Center, Meir 21, 2000 Antwerp, Belgium

**PIONEER ELECTRONICS AUSTRALIA PTY. LTD.**

256-8 City Road, South Melbourne, Victoria 3205, Australia

Printed in Japan

<ARB-087-C>